

# Wire Antennas for Ham Radio

*Iulian Rosu YO3DAC / VA3IUL,*

<http://www.qsl.net/va3iul>

- 01 - Tee Antenna
- 02 - Half-Lambda Tee Antenna
- 03 - Twin-Led Marconi Antenna
- 04 - Swallow-Tail Antenna
- 05 - Random Length Radiator Wire Antenna
- 06 - Windom Antenna
- 07 - Windom Antenna - Feed with coax cable
- 08 - Quarter Wavelength Vertical Antenna
- 09 - Folded Marconi Tee Antenna
- 10 - Zeppelin Antenna
- 11 - EWE Antenna
- 12 - Dipole Antenna - Balun
- 13 - Multiband Dipole Antenna
- 14 - Inverted-Vee Antenna
- 15 - Sloping Dipole Antenna
- 16 - Vertical Dipole
- 17 - Delta Fed Dipole Antenna
- 18 - Bow-Tie Dipole Antenna
- 19 - Bow-Tie Folded Dipole Antenna for RX
- 20 - Multiband Tuned Doublet Antenna
- 21 - G5RV Antenna
- 22 - Wideband Dipole Antenna
- 23 - Wideband Dipole for Receiving
- 24 - Tilted Folded Dipole Antenna
- 25 - Right Angle Marconi Antenna
- 26 - Linearly Loaded Tee Antenna
- 27 - Reduced Size Dipole Antenna
- 28 - Doublet Dipole Antenna
- 29 - Delta Loop Antenna
- 30 - Half Delta Loop Antenna
- 31 - Collinear Franklin Antenna
- 32 - Four Element Broadside Antenna
- 33 - The Lazy-H Array Antenna
- 34 - Sterba Curtain Array Antenna
- 35 - T-L DX Antenna
- 36 - 1.9 MHz Full-wave Loop Antenna
- 37 - Multi-Band Portable Antenna
- 38 - Off-center-fed Full-wave Doublet Antenna
- 39 - Terminated Sloper Antenna
- 40 - Double Extended Zepp Antenna
- 41 - TCFTFD Dipole Antenna
- 42 - Vee-Sloper Antenna
- 43 - Rhombic Inverted-Vee Antenna
- 44 - Counterpoise Longwire
- 45 - Bisquare Loop Antenna
- 46 - Piggyback Antenna for 10m
- 47 - Vertical Sleeve Antenna for 10m
- 48 - Double Windom Antenna
- 49 - Double Windom for 9 Bands
- 50 - Collinear Trap Antenna
- 51 - Short Dipole Antenna for 40m - 80m - 160m
- 52 - Center Fed-Zepp Antenna for 80m - 40m
- 53 - All-Bands Antenna
- 54 - All-Bands Dipole Antenna
- 55 - Multiband Z Antenna
- 56 - Multiband Dipole Antenna
- 57 - Five-Bands No-Tuner Antenna
- 58 - Dualband Full-wave Loop Antenna for 80m-40m
- 59 - Loop Antenna for 10m
- 60 - Lazy Quad Antenna for 10m
- 61 - Tri-band Delta Loop Antenna for 80m - 40m - 30m
- 62 - Dual-band Loop Antenna for 30m - 40m
- 63 - Wire-Beam Antenna for 80m
- 64 - Dual-Band Sloper Antenna
- 65 - Inverted-V Beam Antenna for 30m
- 66 - ZL-Special Beam Antenna for 15m
- 67 - Half-Sloper Antenna for 160m
- 68 - Two-Bands Half Sloper for 80m - 40m
- 69 - Linear Loaded Sloper Antenna for 160m
- 70 - Super-Sloper Antenna
- 71 - Tower Pole as a Vertical Antenna for 80m
- 72 - Clothesline Antenna

73 - Curtain Zepp Antenna for 160m, 80m, 40m  
74 - Collinear Array Antenna for 40m, 30m, 20m  
75 - 160m Inverted Delta Loop  
76 - Half Rhombic Unidirectional Vertical for 20m to 6m  
77 - Capacitance Loaded Vertical Antenna for 160m  
78 - Fan Dipole Antenna for 80m to 6m  
79 - Wire Ground Plane Antenna  
80 - Inverted Delta Loop Antenna for 160m  
81 - Inverted-L for 160m  
82 - 300ohm-Ribbon Dual Band Dipole  
83 - Tri-Band Beam for 20m, 15m, 10m  
84 - Mini-Horse Yagi Antenna  
85 - Backpack J-Pole Antenna for 10m, 6m, 2m  
86 - Fan-Dipole Antenna for 80m to 6m  
87 - Capacity Tuned Folded Loop Antenna for 20m  
88 - Indoor Loop Antenna for 80m to 30m  
89 - Indoor Loop Antenna for 80m  
90 - Double-Delta Antenna 80m and 40m  
91 - Inductance-Loaded Shortened Dipole for 160m  
92 - V-Beam Antenna for 15m  
93 - Picnic Vertical Wire Antenna  
94 - Laid-Back Quad Antenna for 80m  
95 - Phased Loop Antenna  
96 - Loop Antenna for TX for 160m  
97 - Morgain-Dipole Antenna for 160m and 80m  
98 - ZL-Special for 20m, 15m, 10m  
99 - Biconical Antenna  
100 - Directive Delta-Birdcage Antenna for 20m to 10m  
101 - Dual Polarization Antenna for 80m and 40m  
102 - Directive 300-ohm-Ribbon Folded Dipole for 15m  
103 - Miniature Directive Antenna for 10m  
104 - Biquad Antenna 12dBi-Gain for 2.4GHz  
105 - Dual-Rhomboid Antenna for 435MHz to 870MHz  
106 - Double-Bazooka Antenna for 80m  
107 - J-Style Antenna  
108 - Vertical / Horizontal / Circular Polarization Antenna  
109 - Coax Inverted-L Antenna for 80m  
110 - Indoor Compact Loop Antenna for 80m  
111 - Helix Antenna  
112 - Novice Vertical Antenna for 80m, 40m, 15m, 10m  
113 - Stub-Loaded Shortened Dipole for 80m  
114 - Six-Band Wire-Stub Trap Antenna for 40m-10m  
115 - Multiband Half-Wave Delta-Loop Antenna  
116 - Hybrid Vee for 20m, 17m  
117 - Six-Shooter Array Antenna, Gain=7.5dB  
118 - Multiband Ground-Plane Antenna for 10m, 15m, 20m  
119 - Wire Superbeam Antenna for 10m, 15m, 20m  
120 - Two Elements Delta-Loop Antenna  
121 - Sterba Curtain Antenna  
122 - Half-Wave Vertical Zepp Antenna  
123 - Lazy-Loop Antenna for 40m  
124 - Terminated Folded Dipole for 80m, 40m  
125 - Short-Fat Antenna for 15m  
126 - Cobra Antenna for 80m  
127 - Log-Periodic Wire Antenna for 20m, 15m, 10m  
128 - 5-Element Log-Periodic Vertical Antenna for 80m, 40m, 20m  
129 - 2m Vertical Wire Antennas  
130 - Earth-Mover Inverted-V Antenna for 40m  
131 - Coax-Cable Collinear Antennas  
132 - Double Bobtail Antenna for 20m  
133 - Collinear Zepp Antenna  
134 - Taylor Vee Antenna for 20m  
135 - Collinear Vertical Antenna 6dB-Gain for 2m, 1.3m, 73cm  
136 - Bi-Loop Antenna for 20m  
137 - Wire Beam 6dBd-Gain for 10m  
138 - Sloping Diamond Antenna 4dB-Gain for 40m  
139 - Twisted Loop Antenna for 160m  
140 - DX RX Loop Antenna for 160m  
141 - Hentenna 3dB-Gain for 10m, 6m, 2m  
142 - VK2AAR Wire Antenna for 20m  
143 - 2-Elements Quad Antenna for 6m  
144 - Hula-Loop Bidirectional 6dB-Gain Antenna for 17m  
145 - Moxon Rectangle Beam for 15m-10m  
146 - Double-D Beam 4dB-Gain  
147 - KE4PT OCEF All-Band Dipole

---

### 01 - Tee Antenna

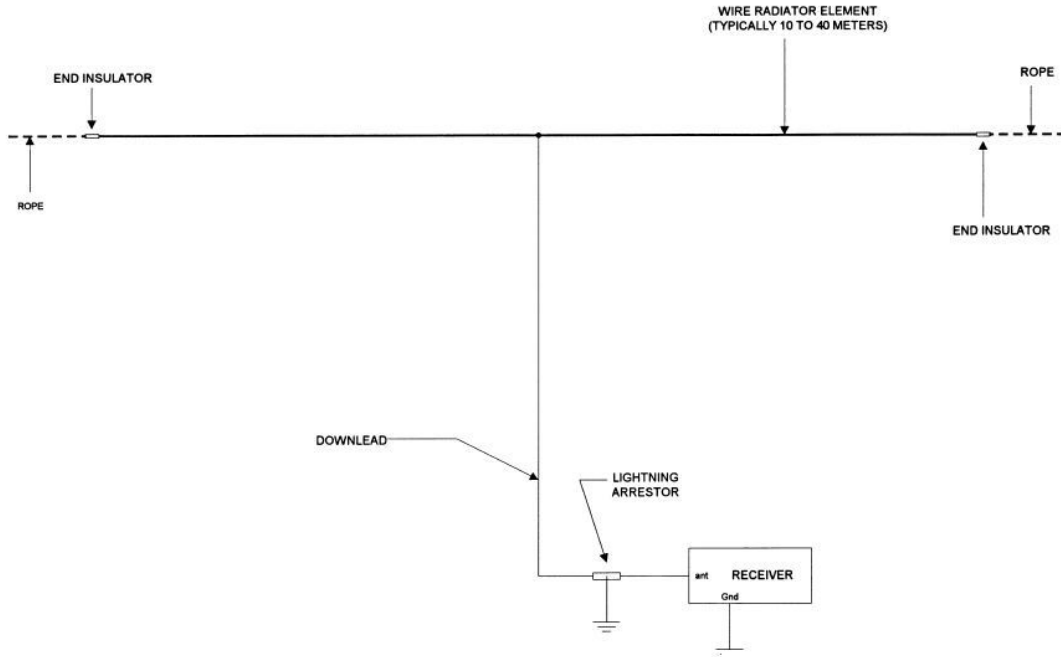

### 02 - Half-Lambda Tee Antenna

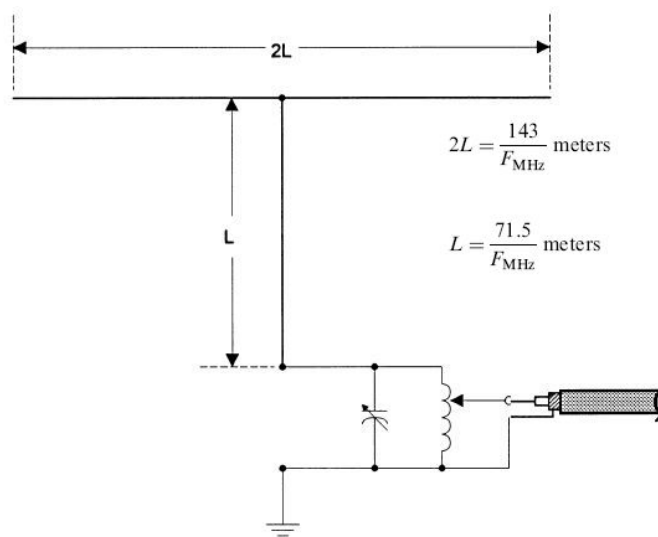

### 03 - Twin-Led Marconi Antenna

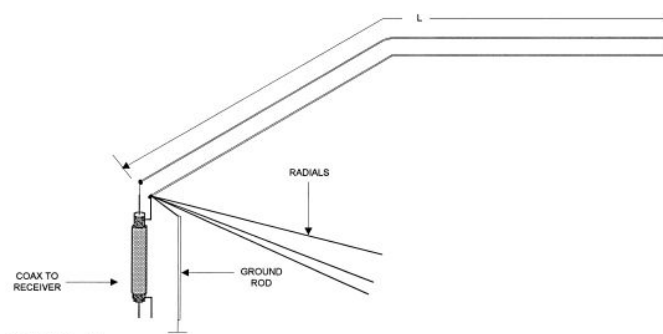

### 04 - Swallow-Tail Antenna

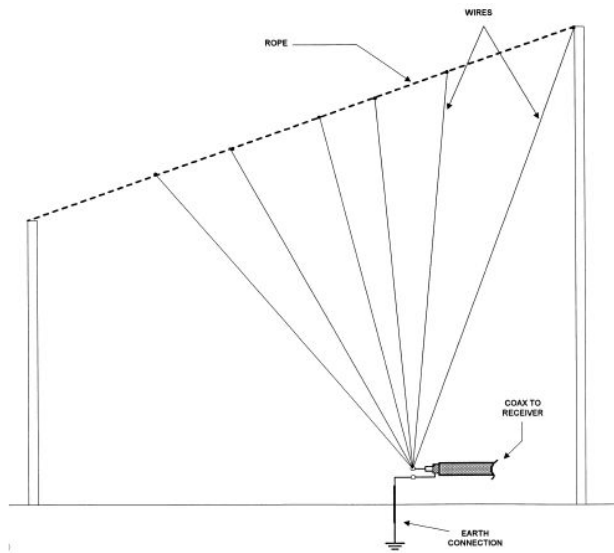

**05 - Random Length Radiator Wire Antenna**

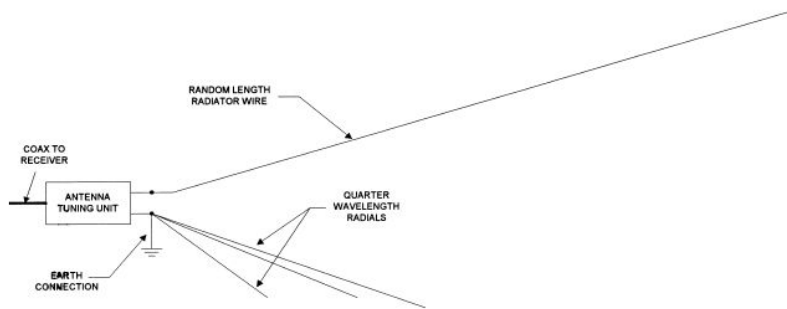

**06 - Windom Antenna**

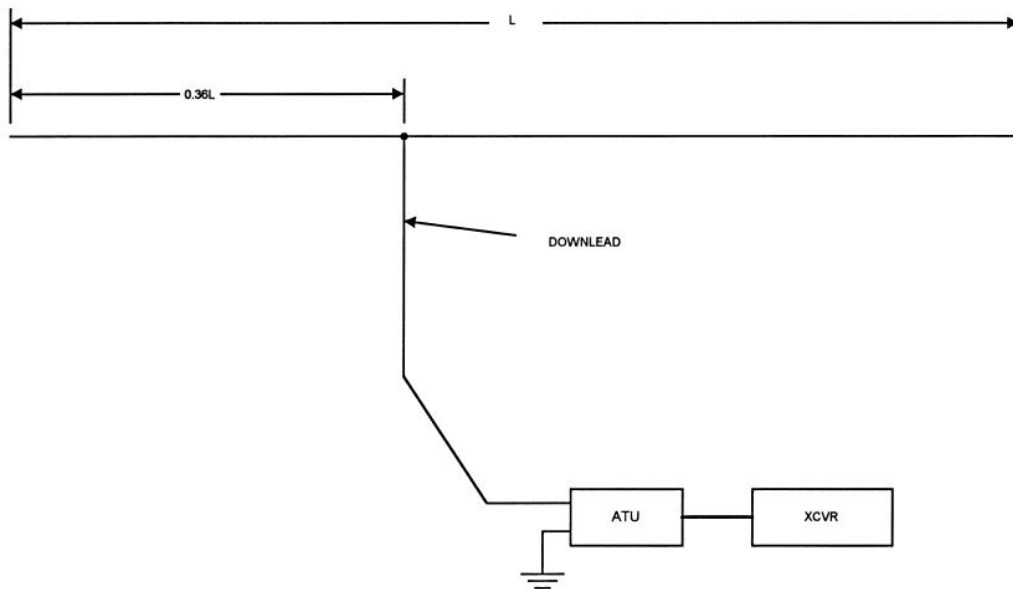

**07 - Windom Antenna - Feed with coax cable**

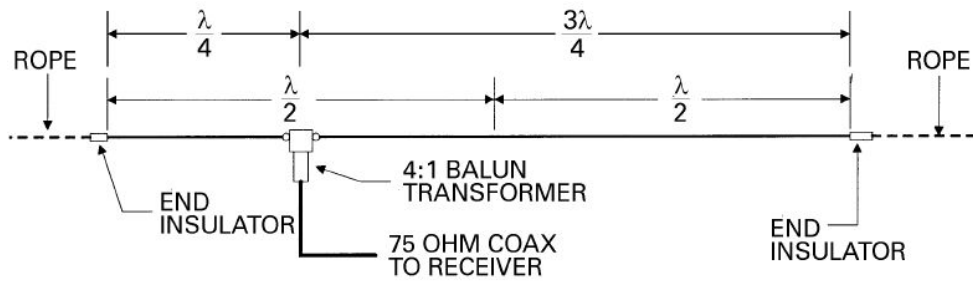

**08 - Quarter Wavelength Vertical Antenna**

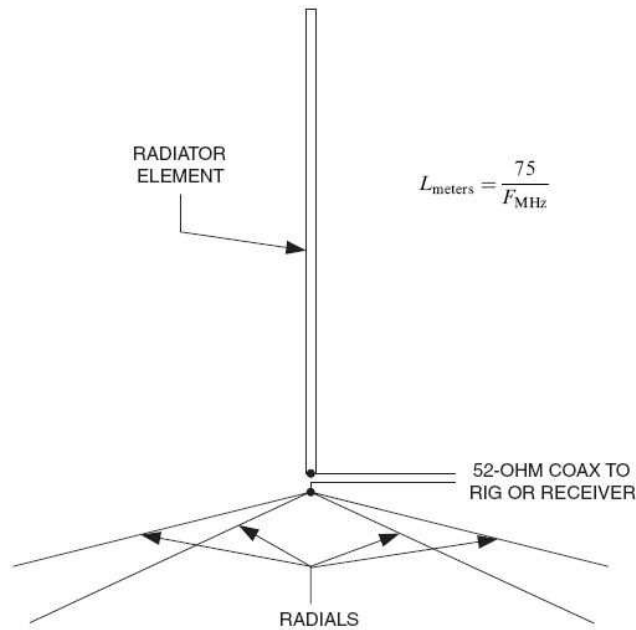

**09 - Folded Marconi Tee Antenna**

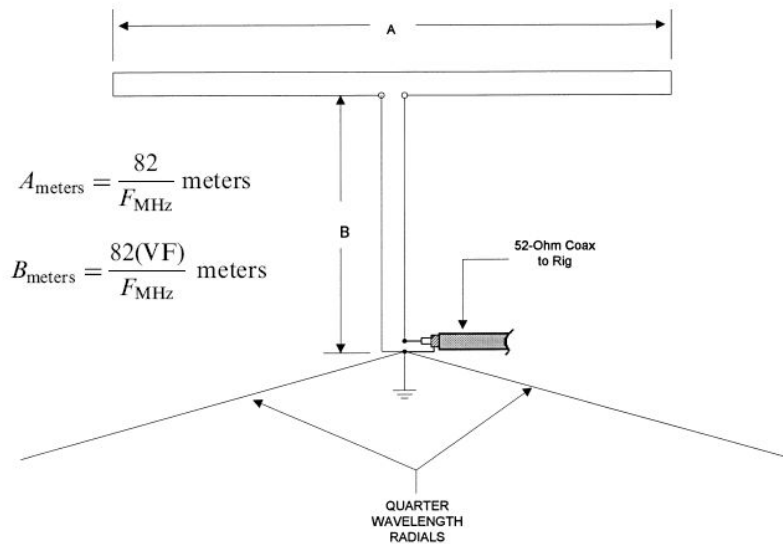

**10 - Zeppelin Antenna**

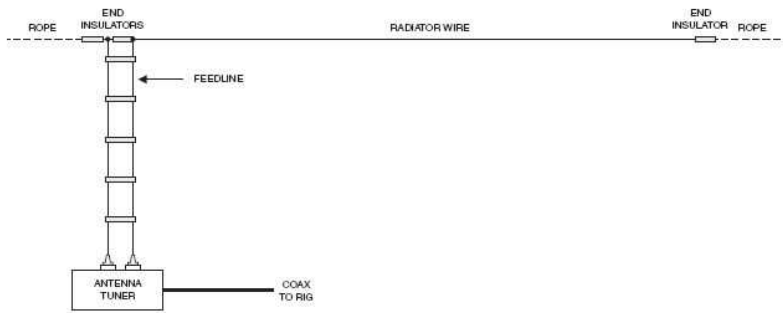

**11 - EWE Antenna**

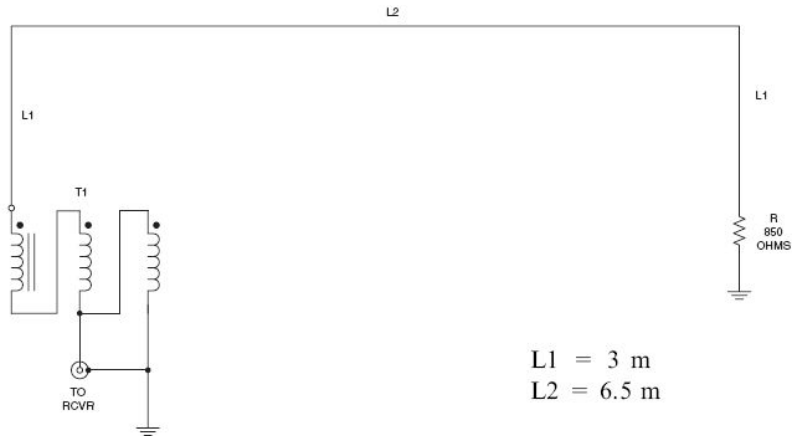

**12 - Dipole Antenna - Balun**

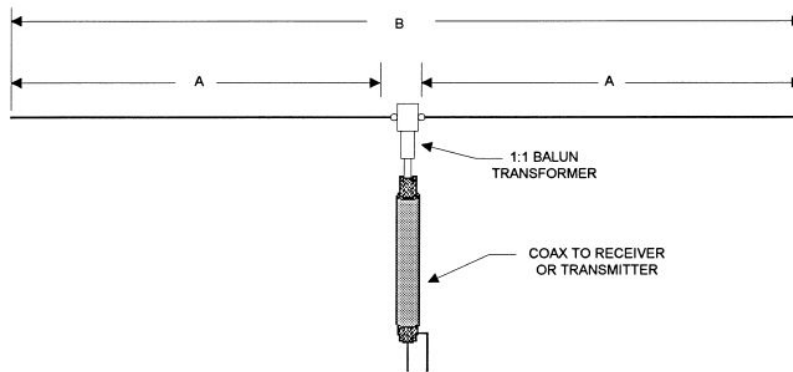

**13 - Multiband Dipole Antenna**

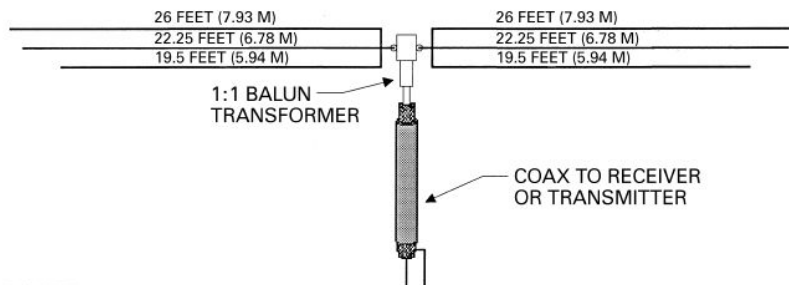

**14 - Inverted-Vee Antenna**

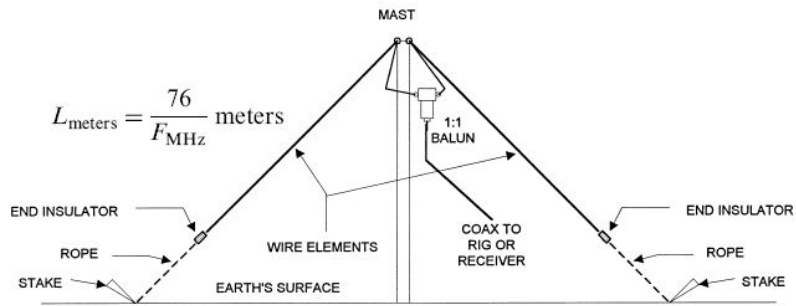

### 15 - Sloping Dipole Antenna

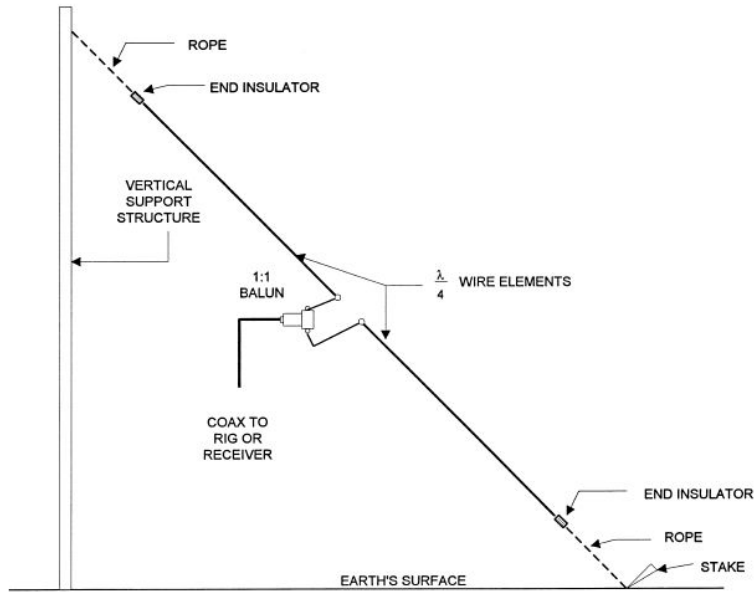

### 16 - Vertical Dipole

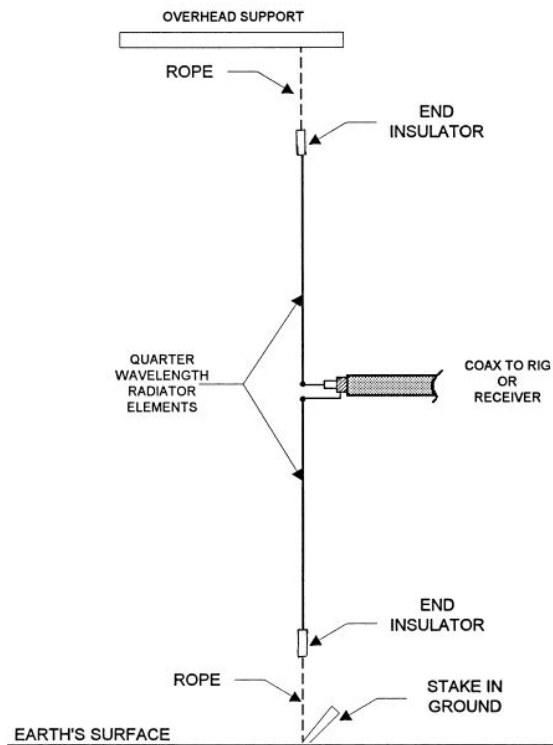

### 17 - Delta Fed Dipole Antenna

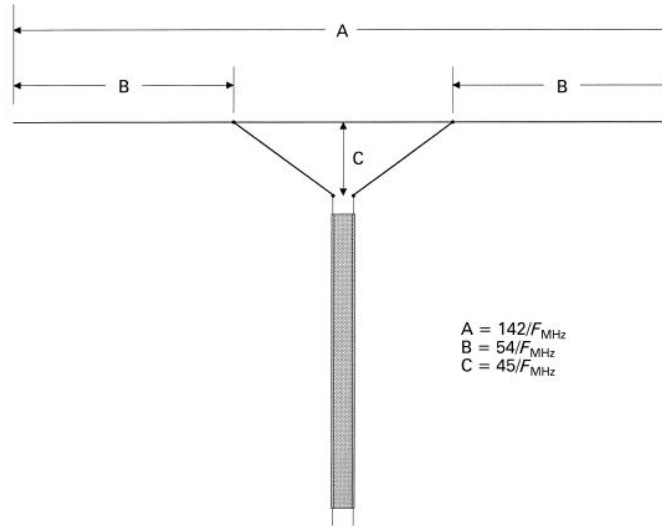

### 18 - Bow-Tie Dipole Antenna

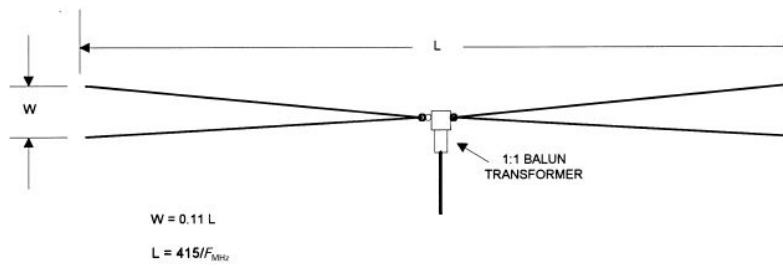

### 19 - Bow-Tie Folded Dipole Antenna for RX

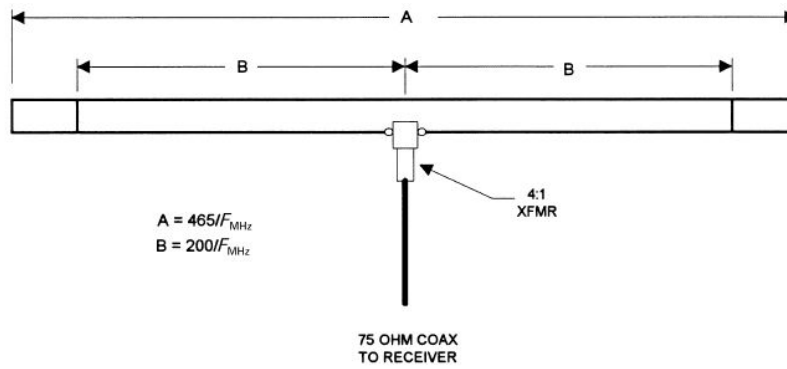

### 20 - Multiband Tuned Doublet Antenna



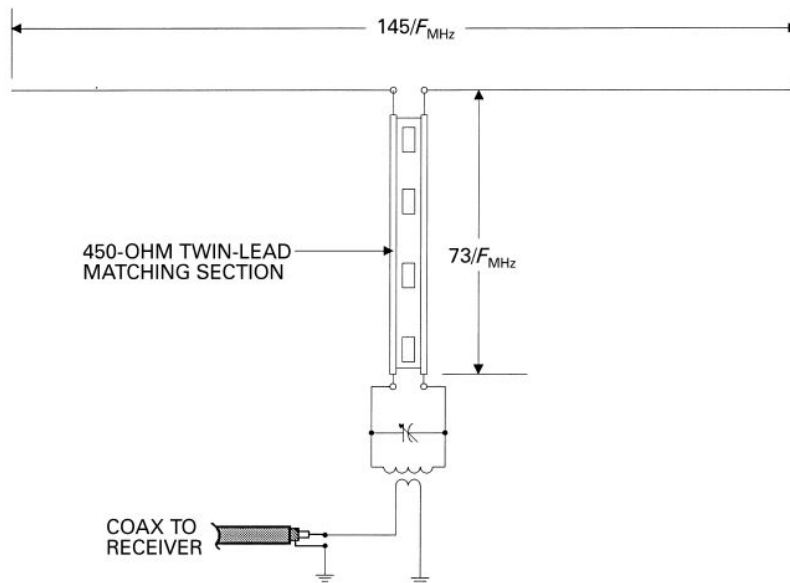

### 21 - G5RV Antenna

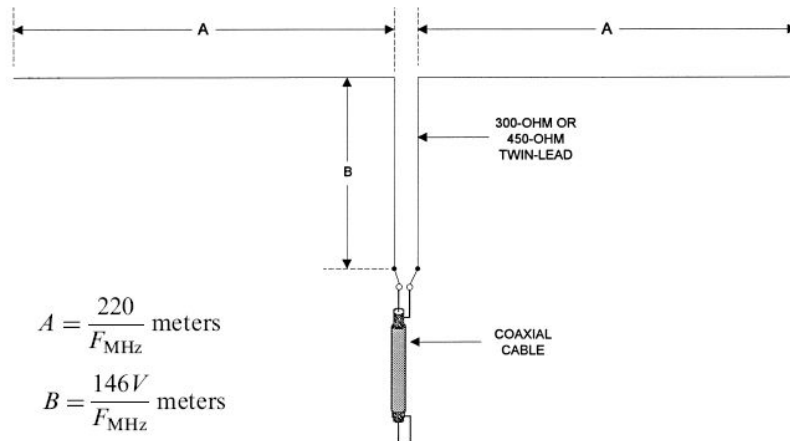

### 22 - Wideband Dipole Antenna

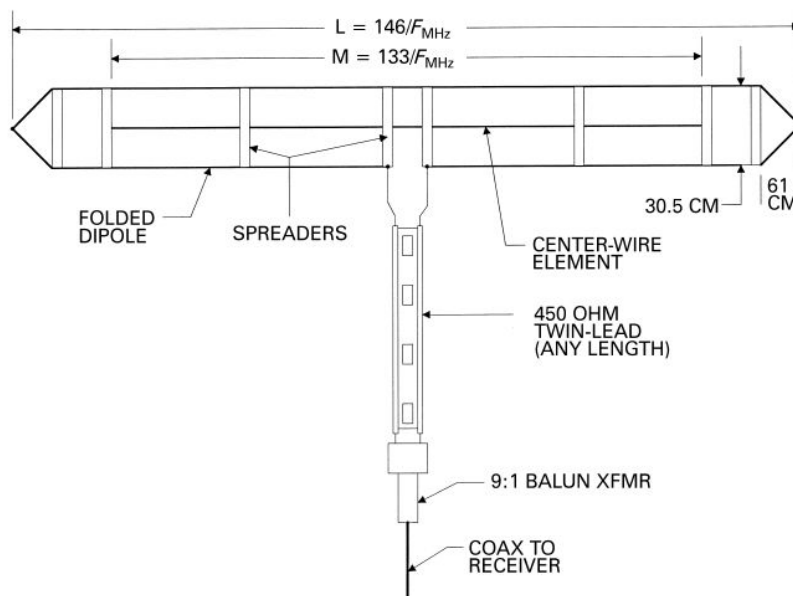

### 23 - Wideband Dipole for Receiving

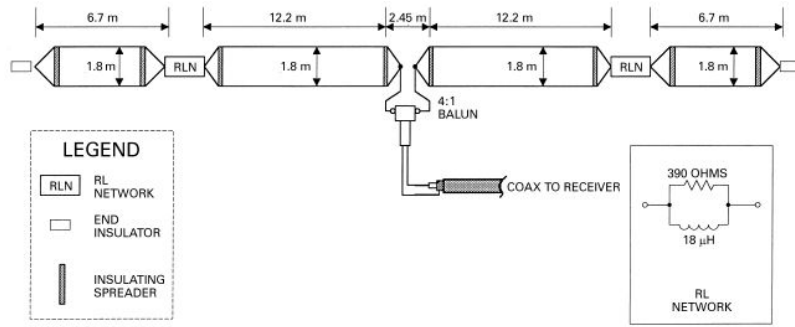

### 24 - Tilted Folded Dipole Antenna

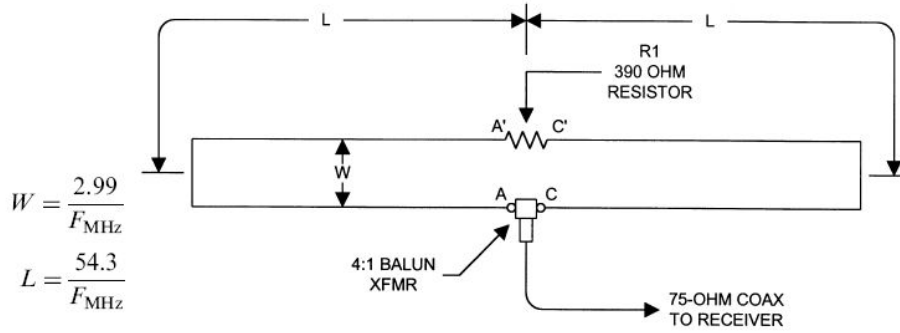

### 25 - Right Angle Marconi Antenna

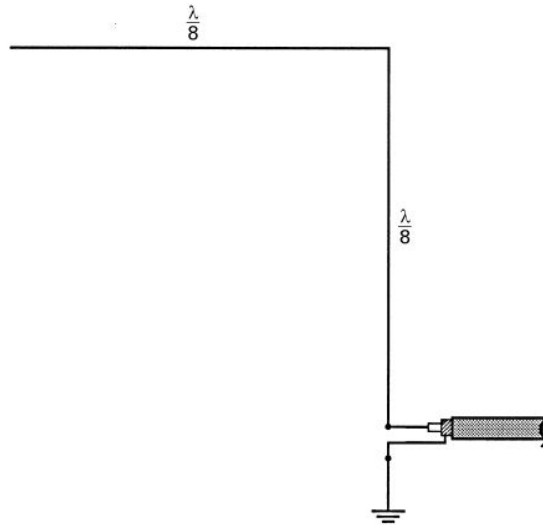

### 26 - Linearly Loaded Tee Antenna

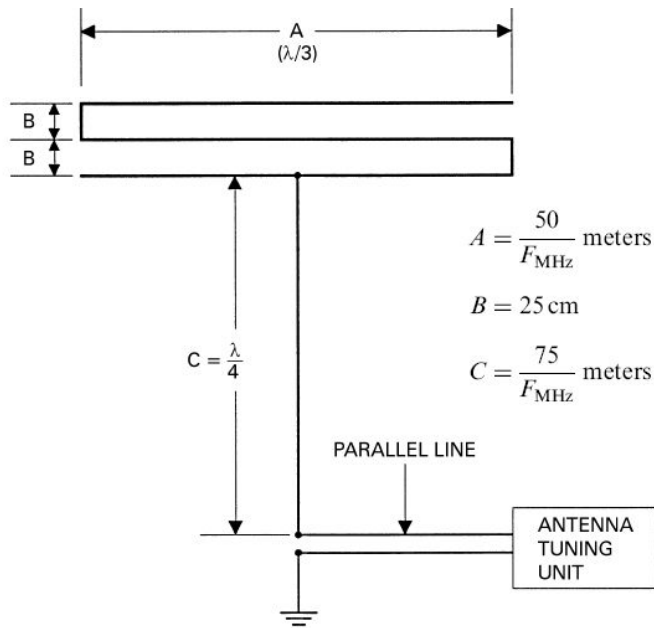

### 27 - Reduced Size Dipole Antenna

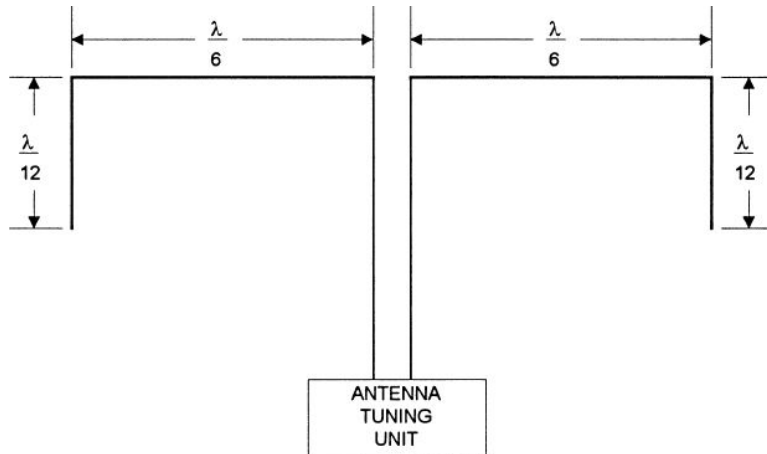

### 28 - Doublet Dipole Antenna

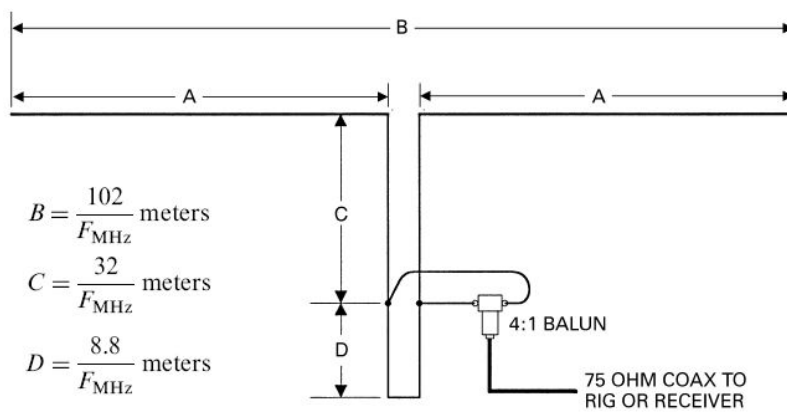

### 29 - Delta Loop Antenna

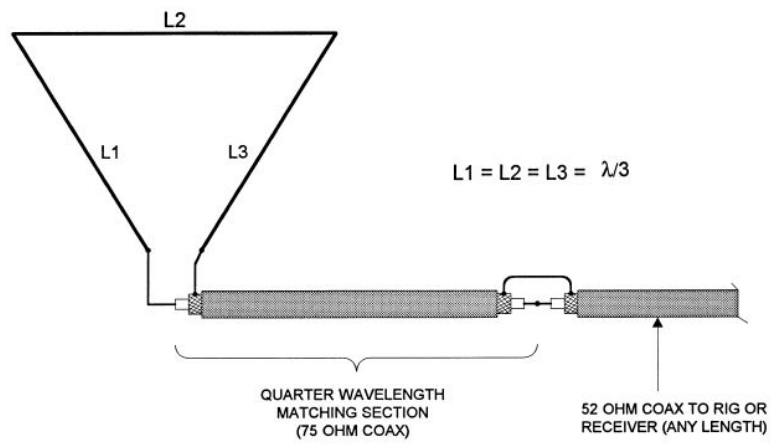

**30 - Half Delta Loop Antenna**

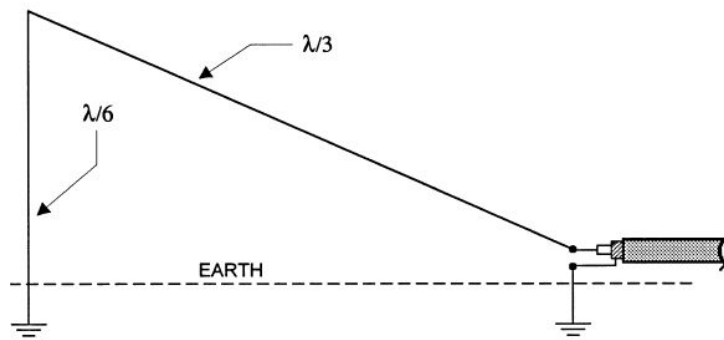

**31 - Collinear Franklin Antenna**

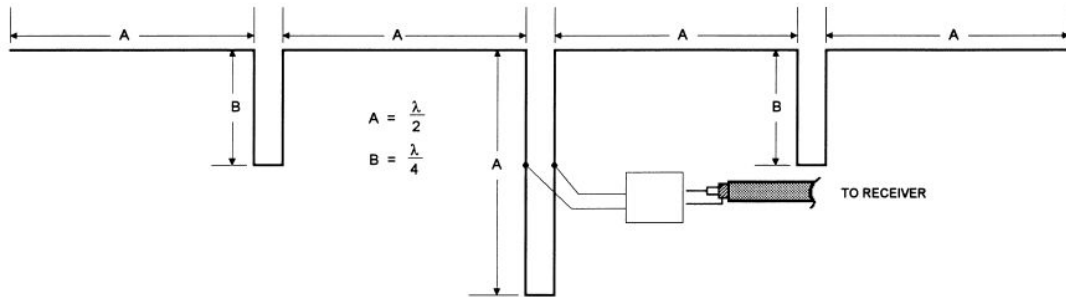

**32 - Four Element Broadside Antenna**

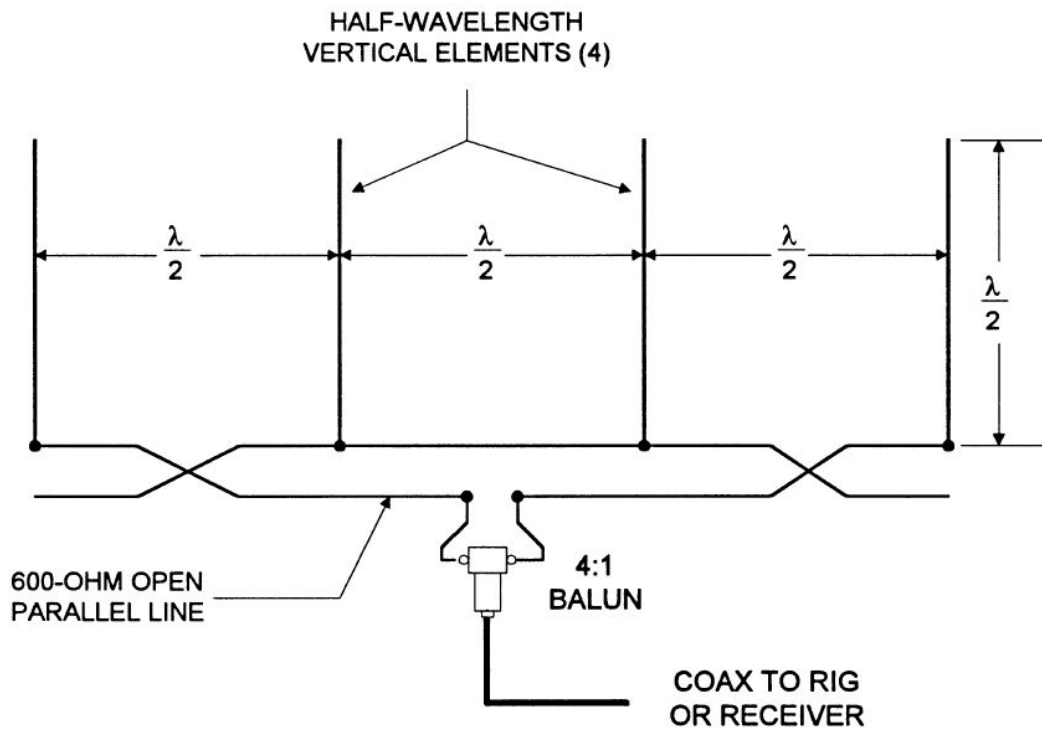

**33 - The Lazy-H Array Antenna**

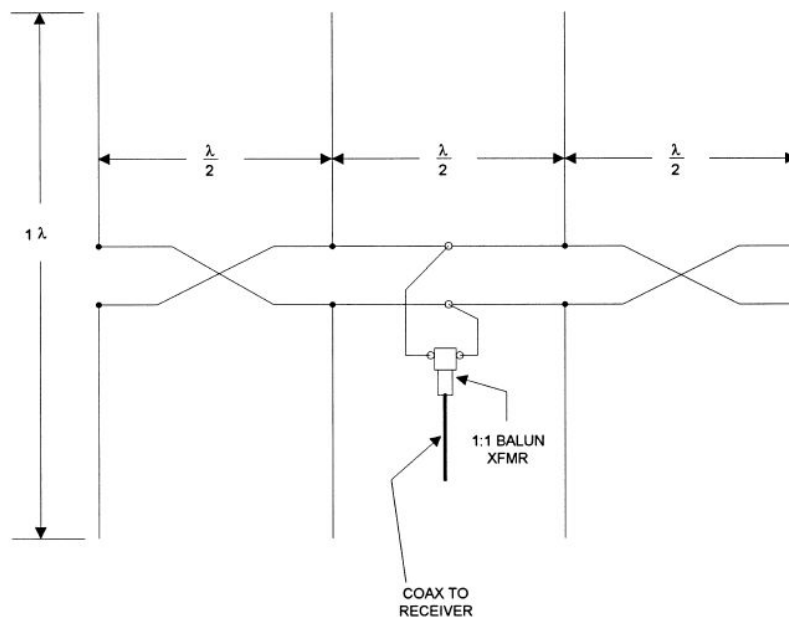

**34 - Sterba Curtain Array Antenna**

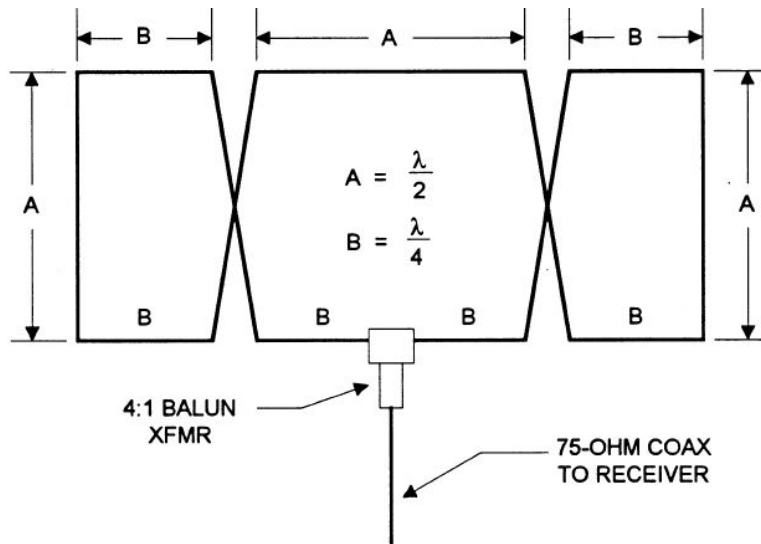

### 35 - T-L DX Antenna

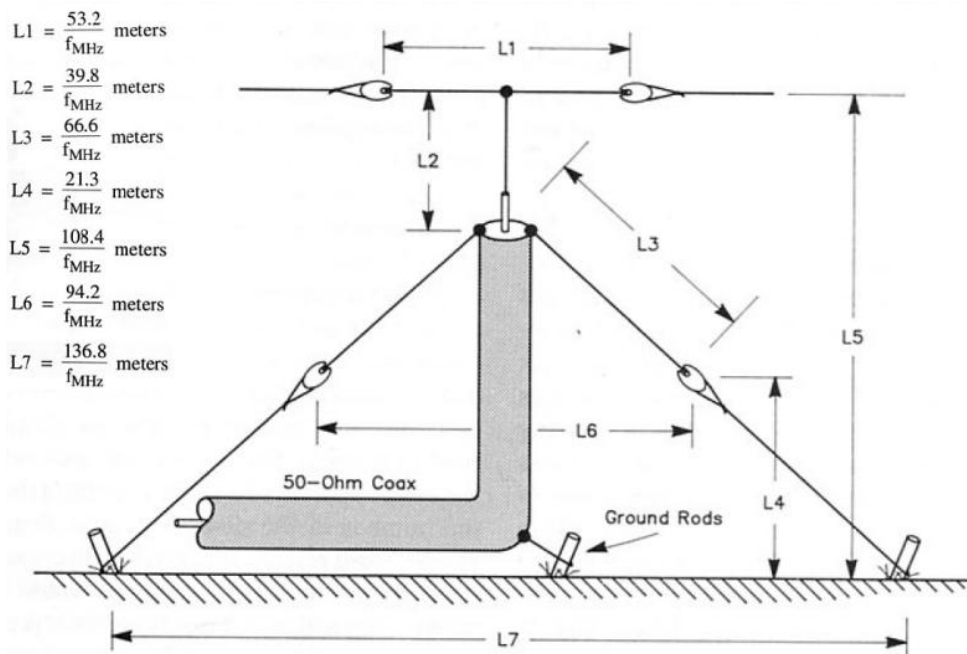

### 36 - 1.9 MHz Full-wave Loop Antenna

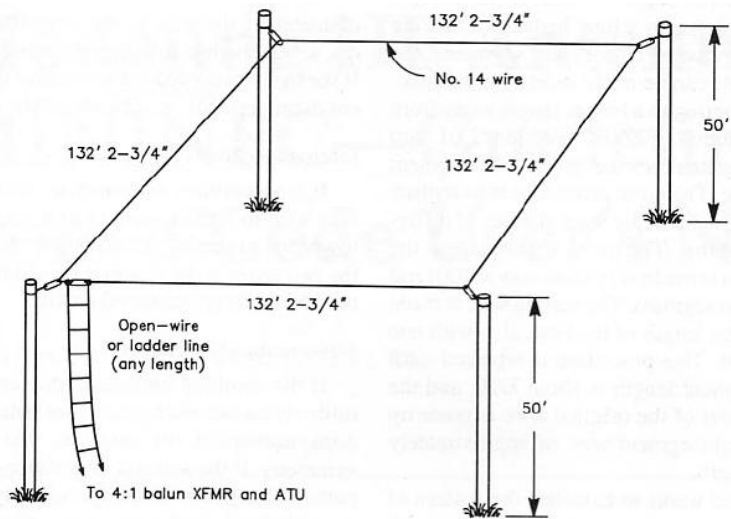

### 37 - Multi-Band Portable Antenna

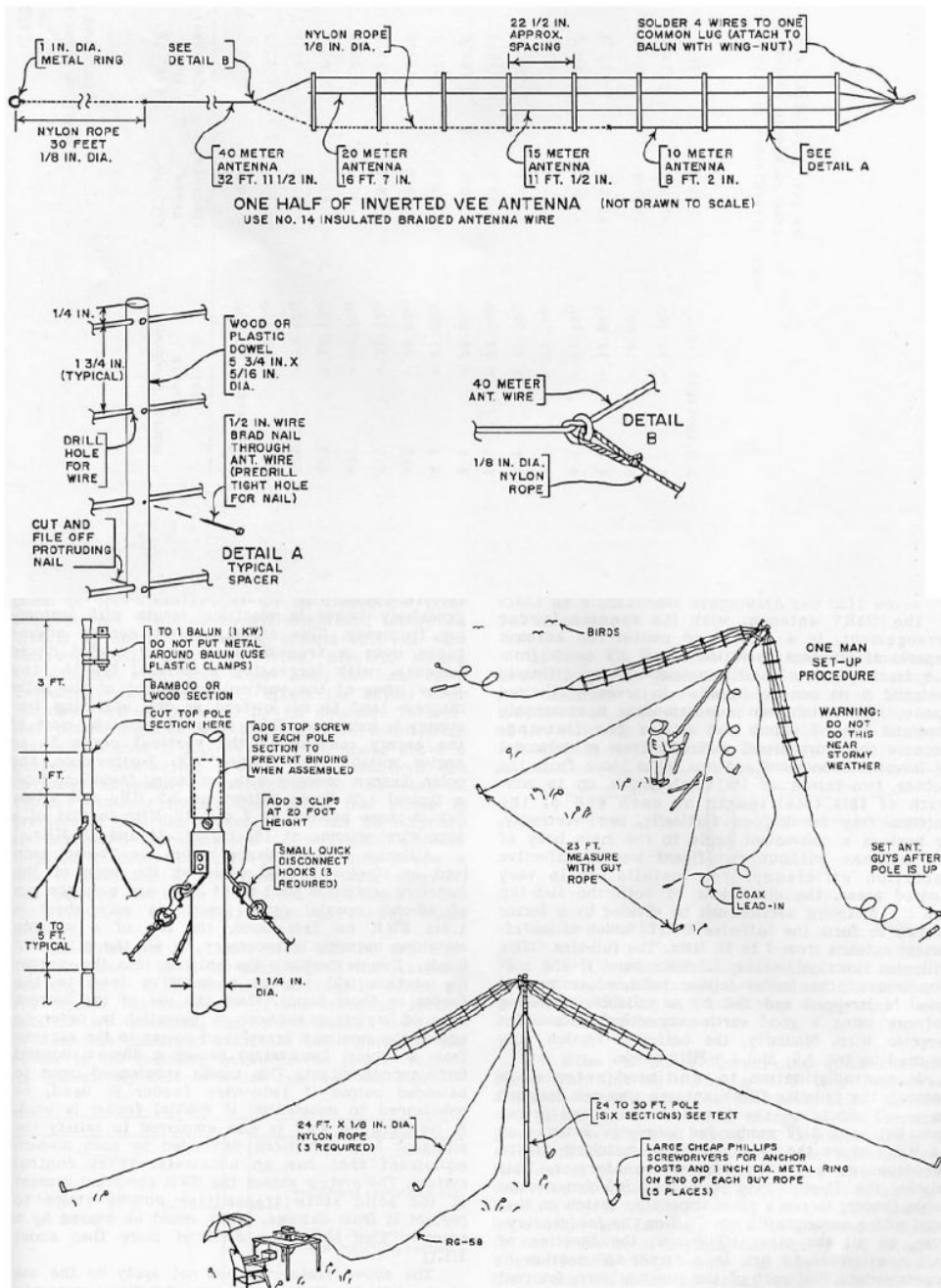

### 38 - Off-center-fed Full-wave Doublet Antenna

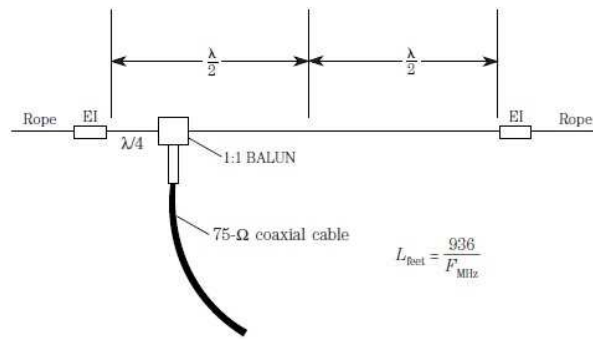

### 39 - Terminated Sloper Antenna

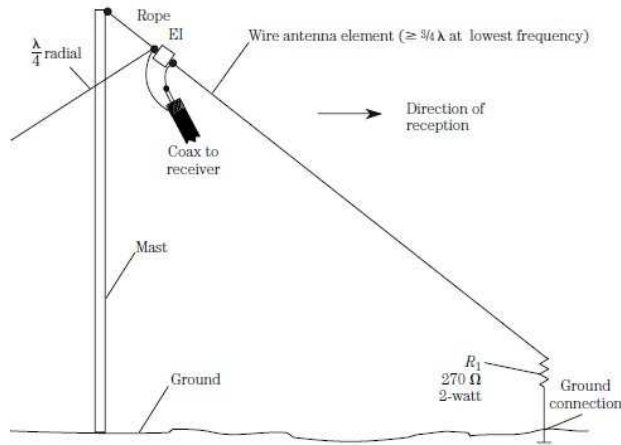

### 40 - Double Extended Zepp Antenna

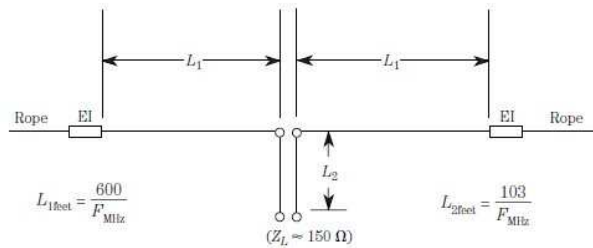

### 41 - TCFTFD Dipole Antenna

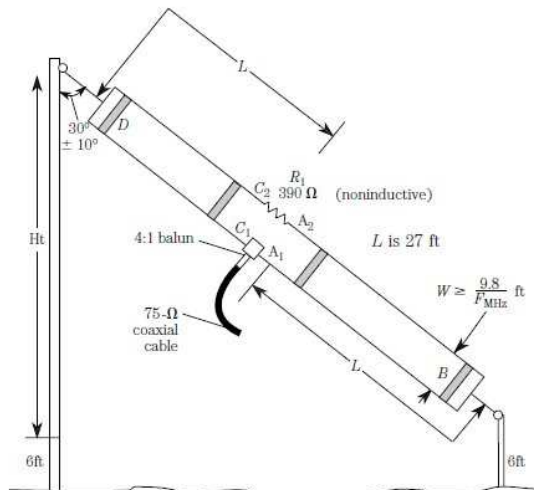



### 42 - Vee-Sloper Antenna

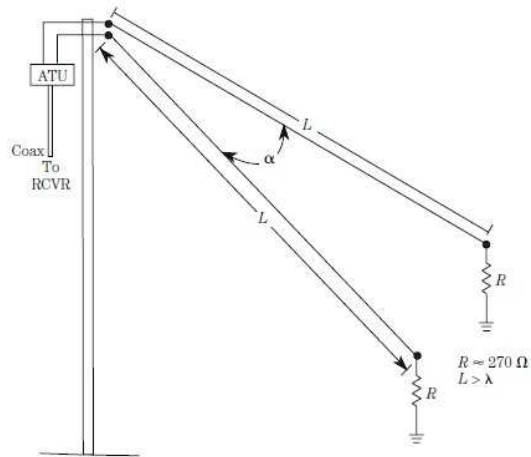

### 43 - Rhombic Inverted-Vee Antenna

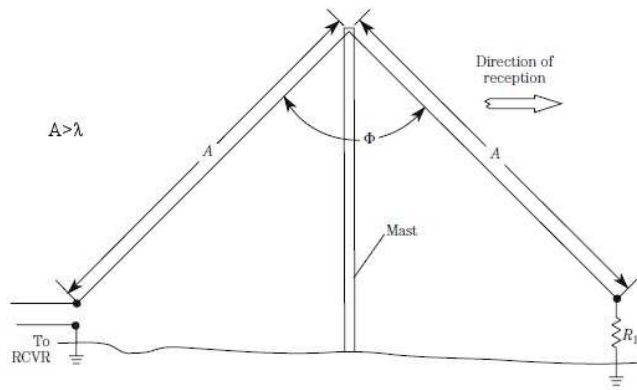

### 44 - Counterpoise Longwire

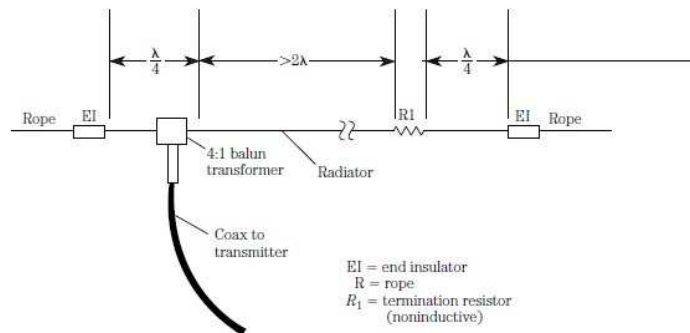

### 45 - Bisquare Loop Antenna

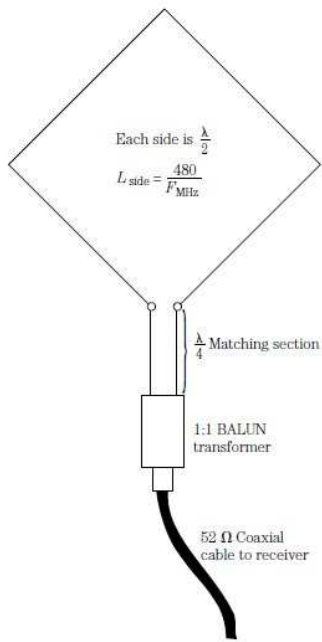

#### 46 - Piggyback Antenna for 10m

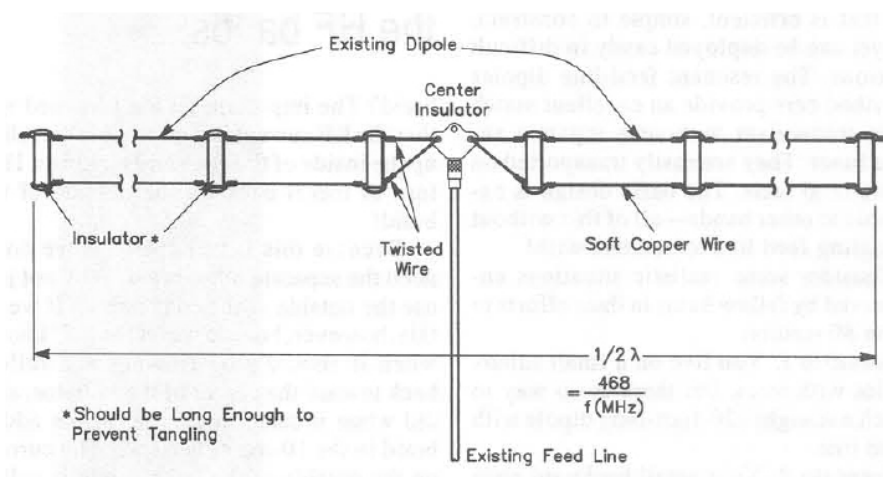

#### 47 - Vertical Sleeve Antenna for 10m

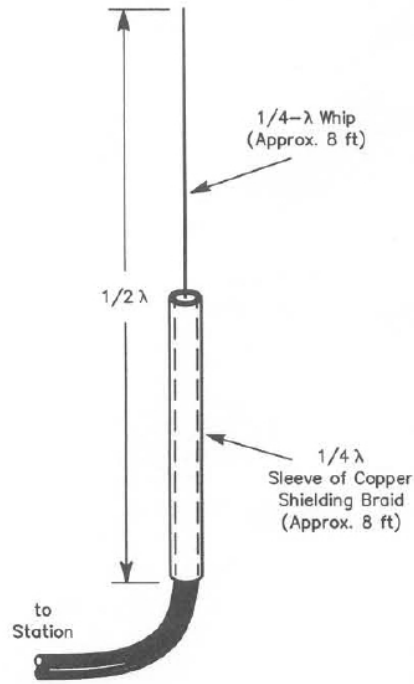

**48 - Double Windom Antenna**

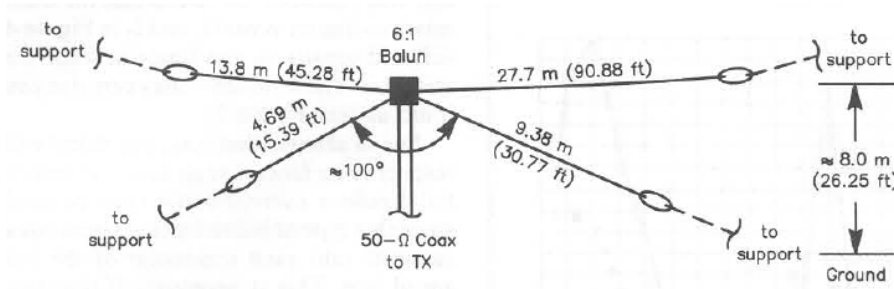

**49 - Double Windom for 9 Bands**

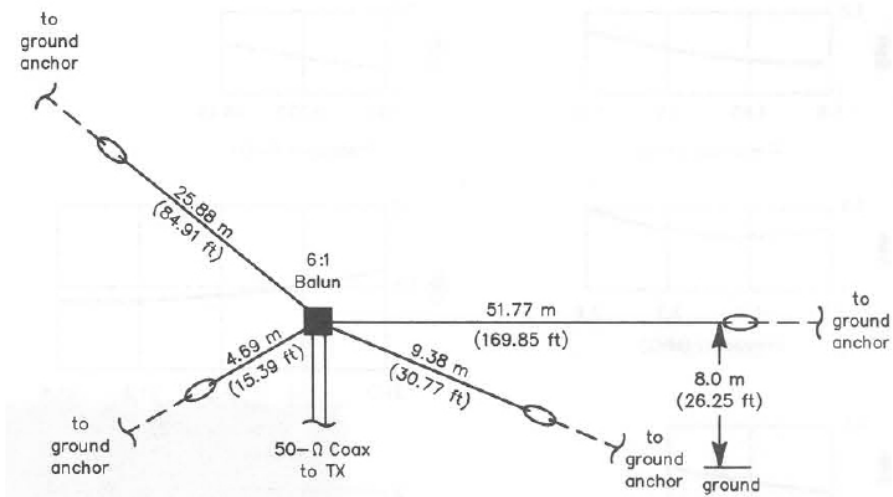

**50 - Collinear Trap Antenna**

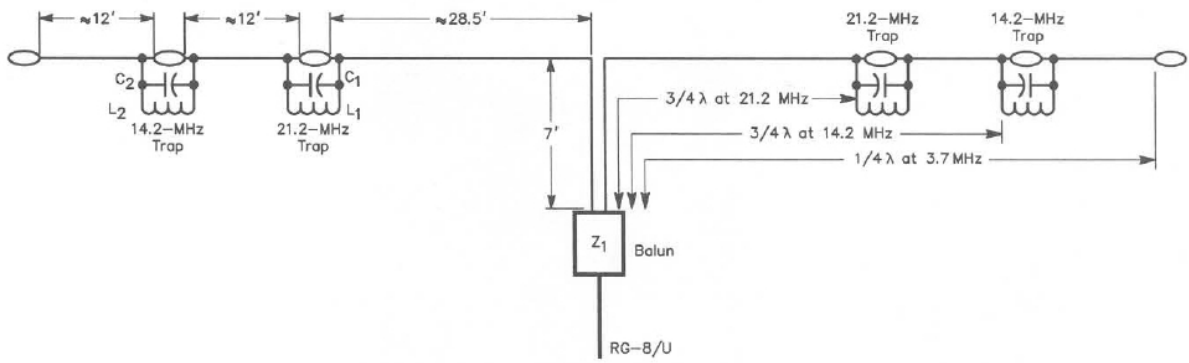

C1, C2—25-pf. 6000-volt disk ceramic. See text.  
 L<sub>1</sub>—Approx. 2  $\mu$ H—4 $\frac{3}{4}$  turns No. 18, 2 $\frac{1}{4}$ -inches diam.,  $\frac{3}{8}$  inch long, or 5 turns No. 18, 2-inch diam., 16 tpi. See text.

L<sub>2</sub>—Approx. 5  $\mu$ H.—8 turns No. 18, 2 $\frac{1}{4}$ -inch dia.,  $\frac{5}{8}$  inch long, or 9 turns No. 18, 2-inch diam. 16 tpi. See text.  
 Z<sub>1</sub>—1 to 1 balun.

### 51 - Short Dipole Antenna for 40m - 80m - 160m

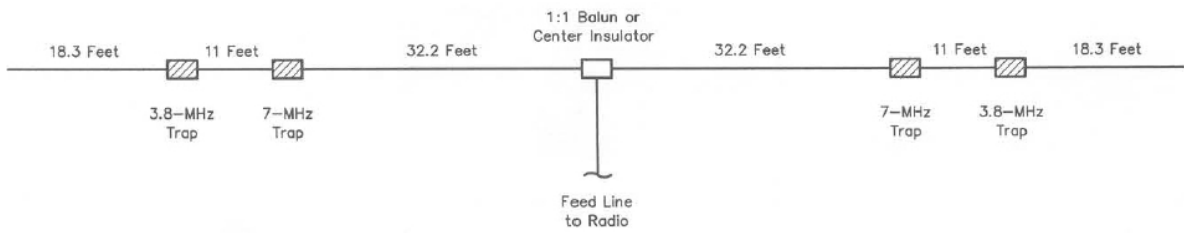

### 52 - Center Fed-Zepp Antenna for 80m - 40m

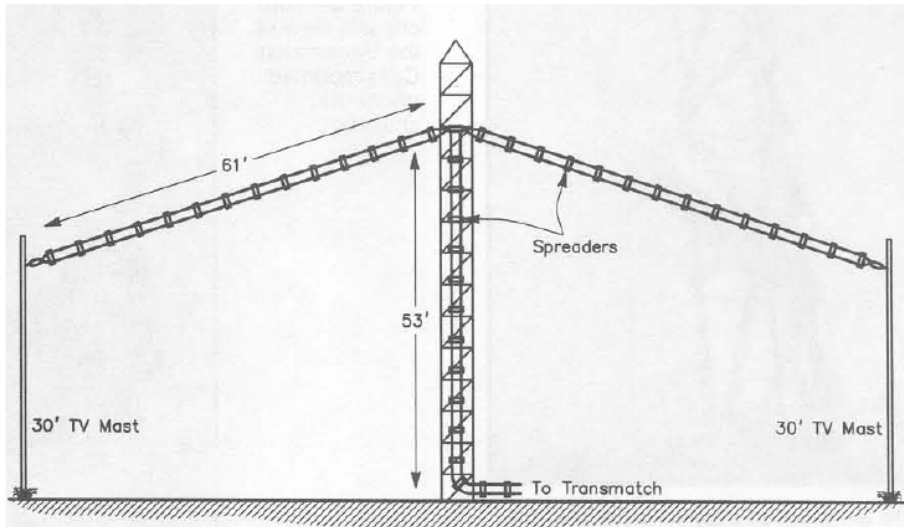

### 53 - All-Bands Antenna

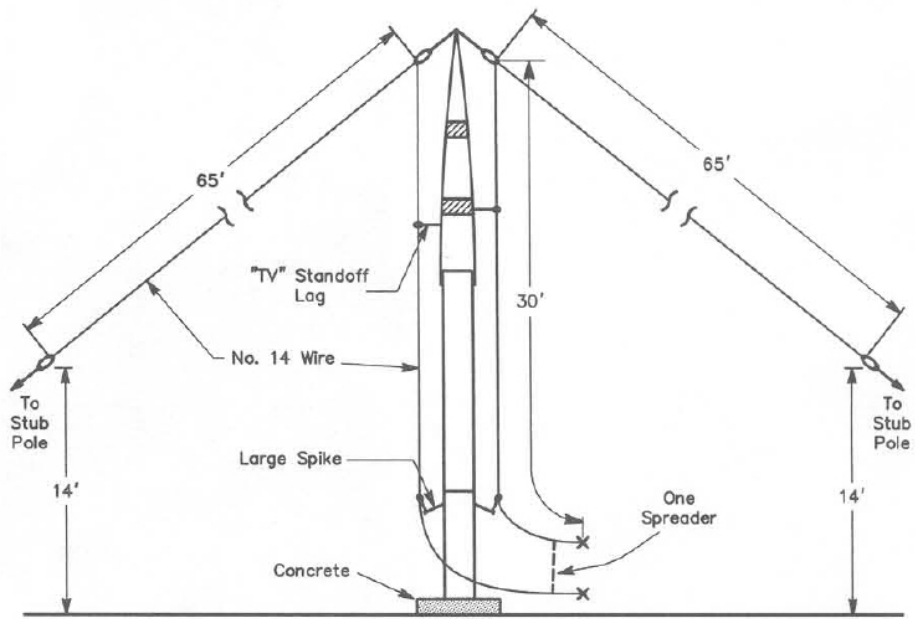

**54 - All-Bands Dipole Antenna**

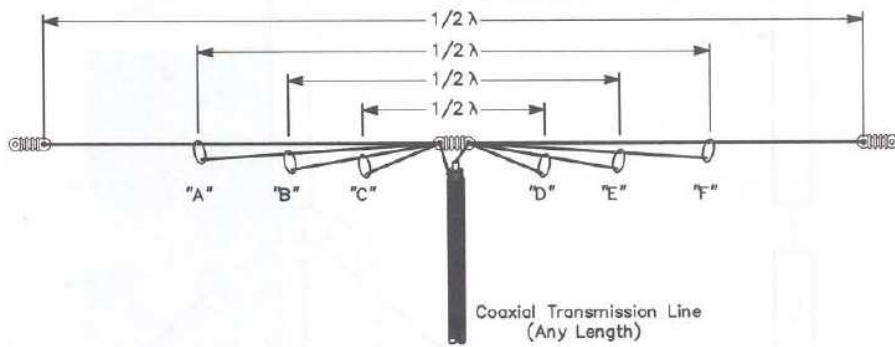

**55 - Multiband Z Antenna**

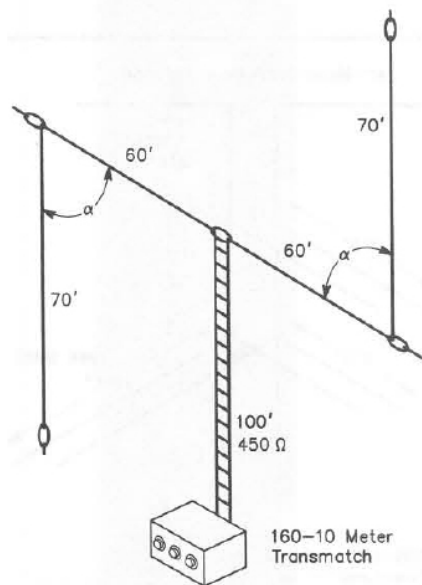

**56 - Multiband Dipole Antenna**

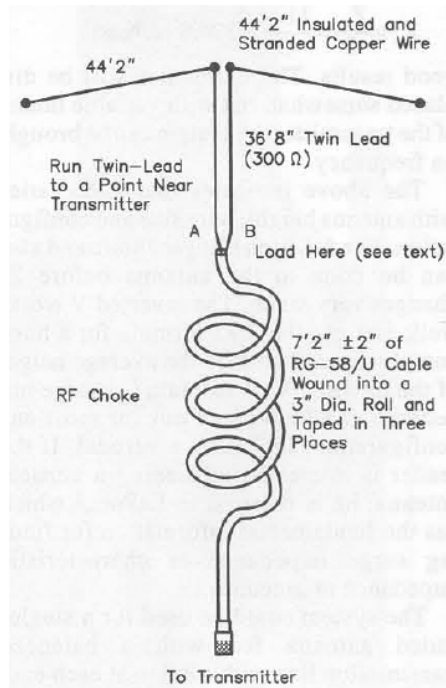

**57 - Five-Bands No-Tuner Antenna**

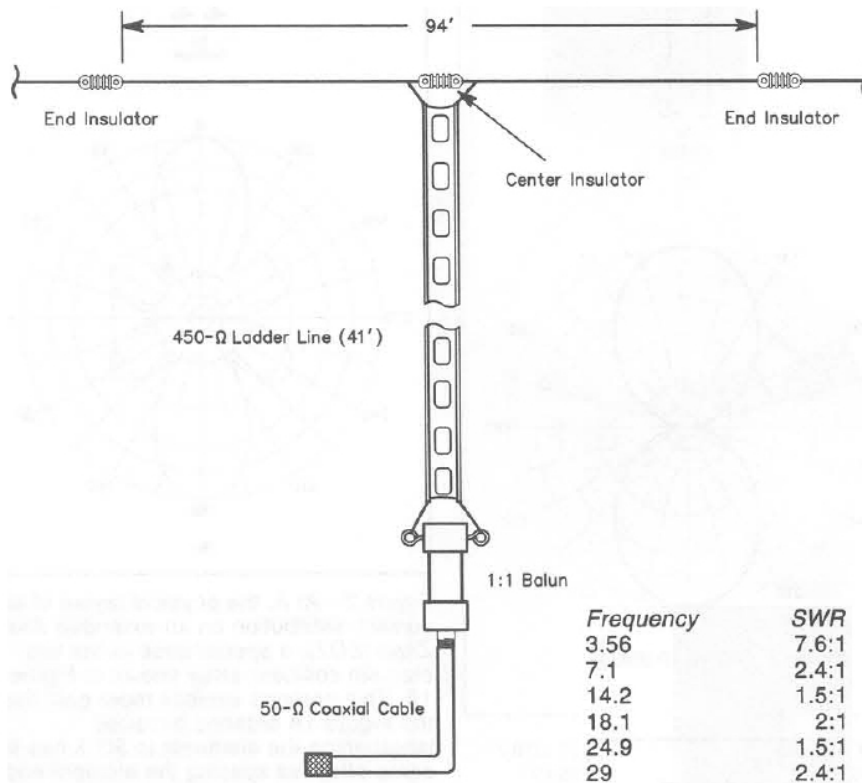

**58 - Dualband Full-wave Loop Antenna for 80m-40m**

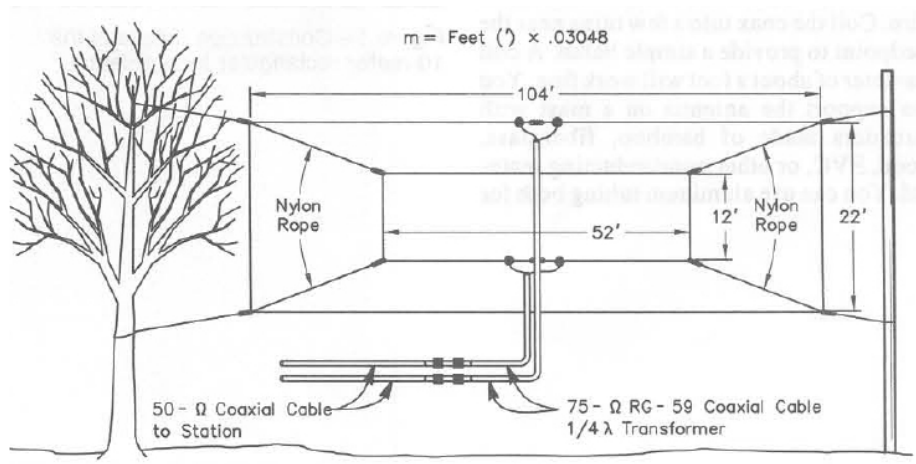

**59 - Loop Antenna for 10m**

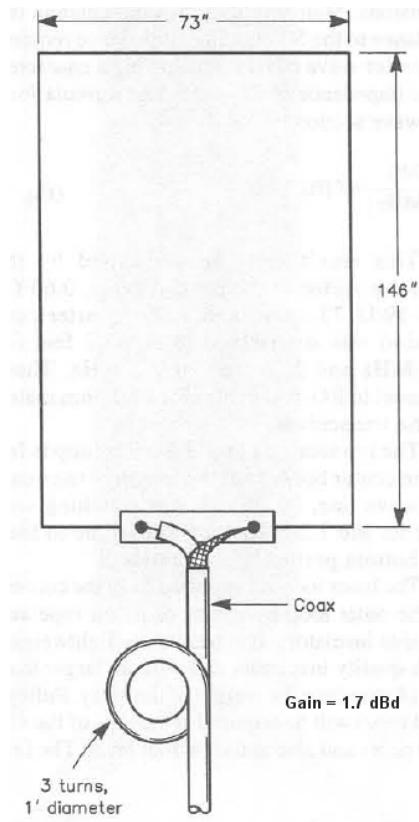

**60 - Lazy Quad Antenna for 10m**

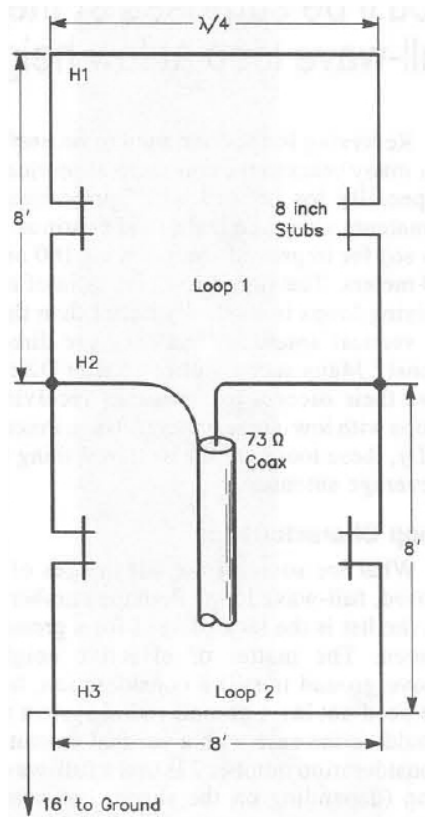

**61 - Tri-band Delta Loop Antenna for 80m - 40m - 30m**

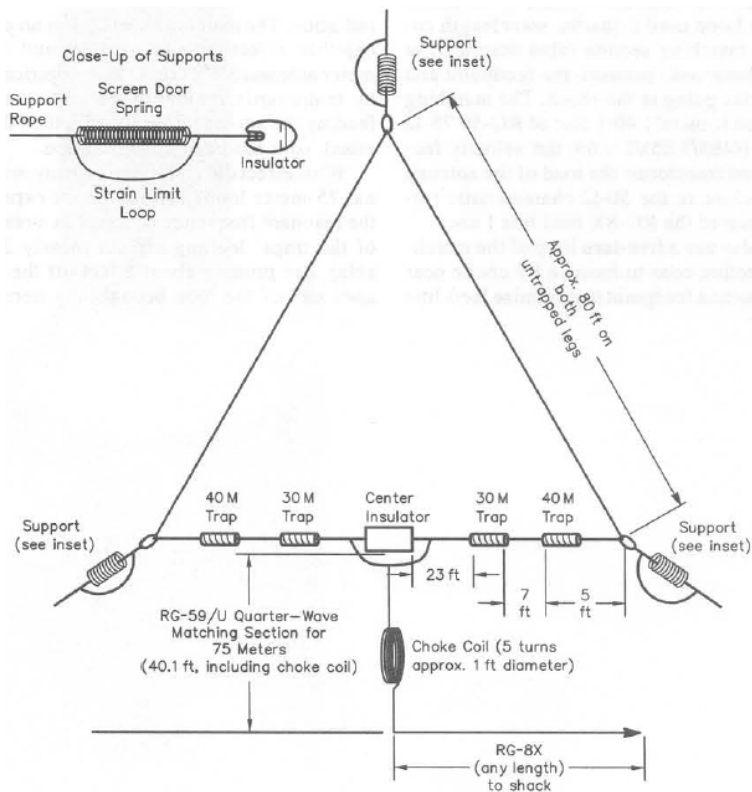

**62 - Dual-band Loop Antenna for 30m - 40m**



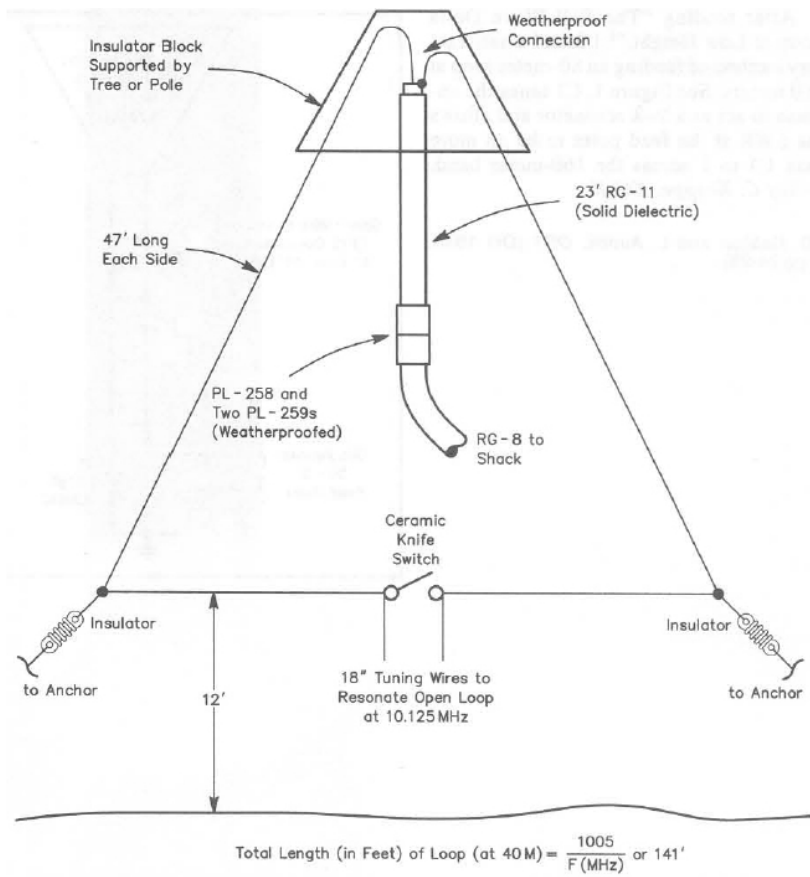

**63 - Wire-Beam Antenna for 80m**

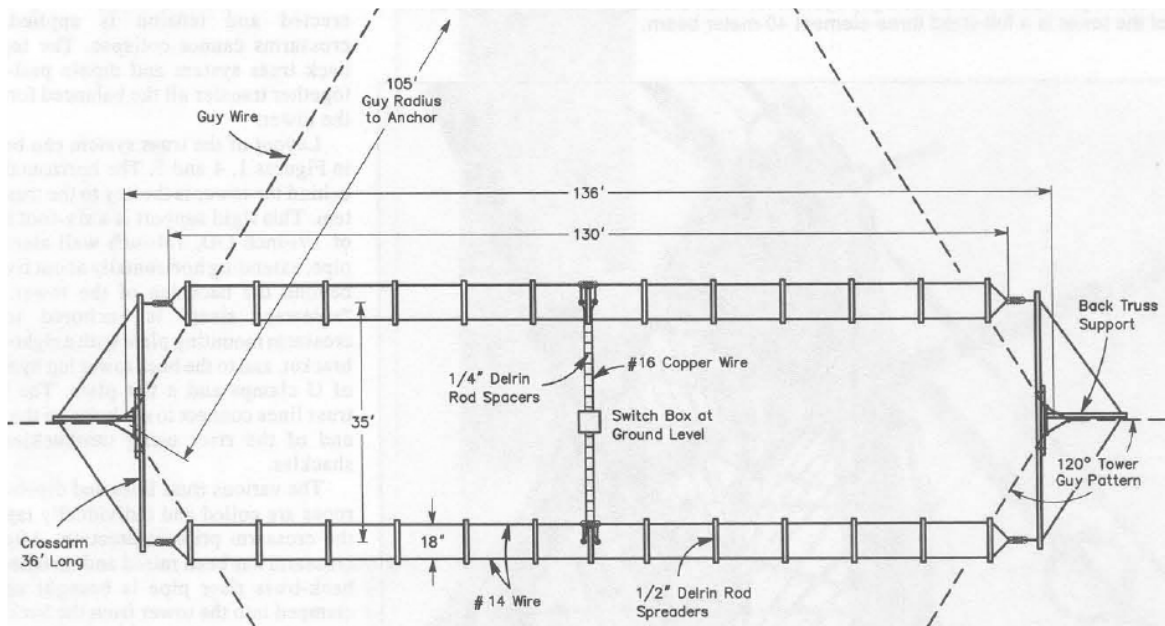

**64 - Dual-Band Sloper Antenna**

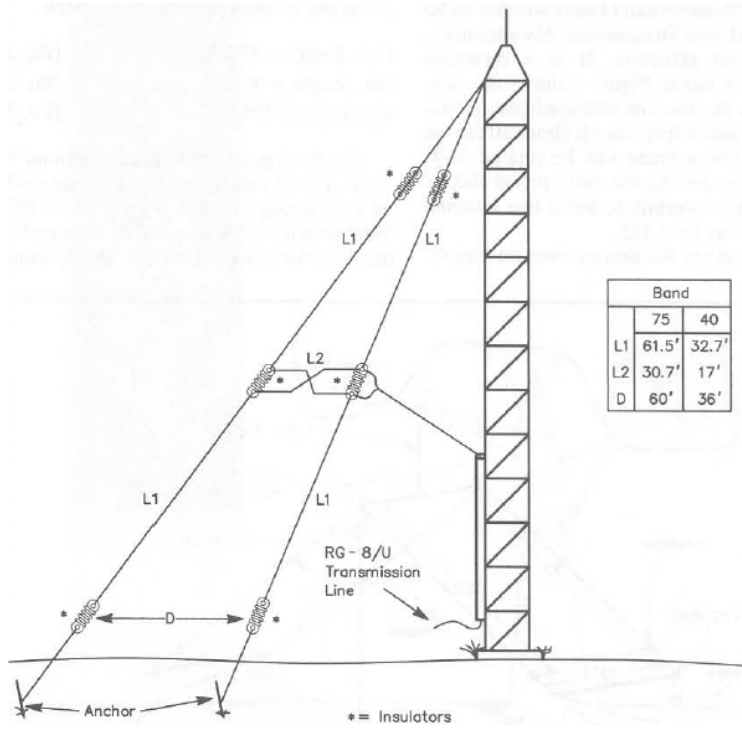

**65 - Inverted-V Beam Antenna for 30m**

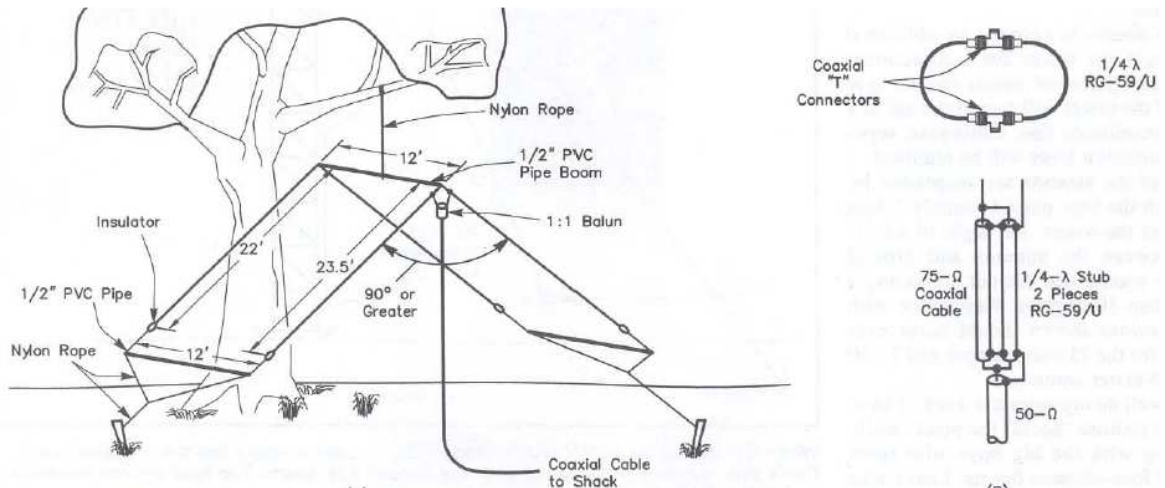

**66 - ZL-Special Beam Antenna for 15m**

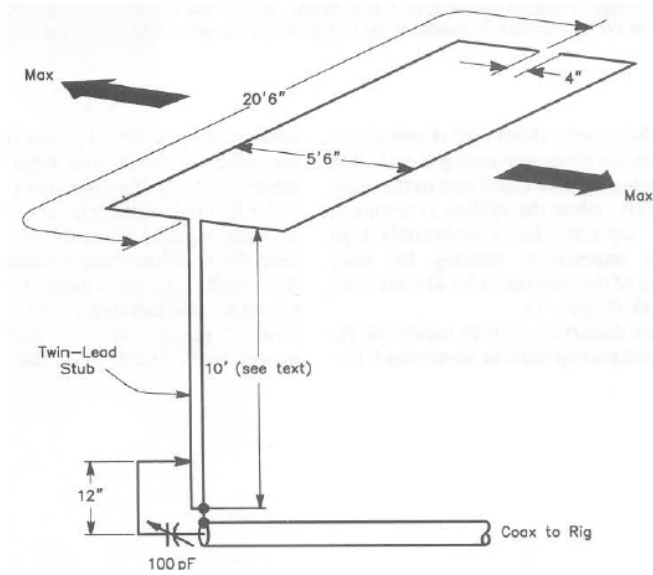

**67 - Half-Sloper Antenna for 160m**

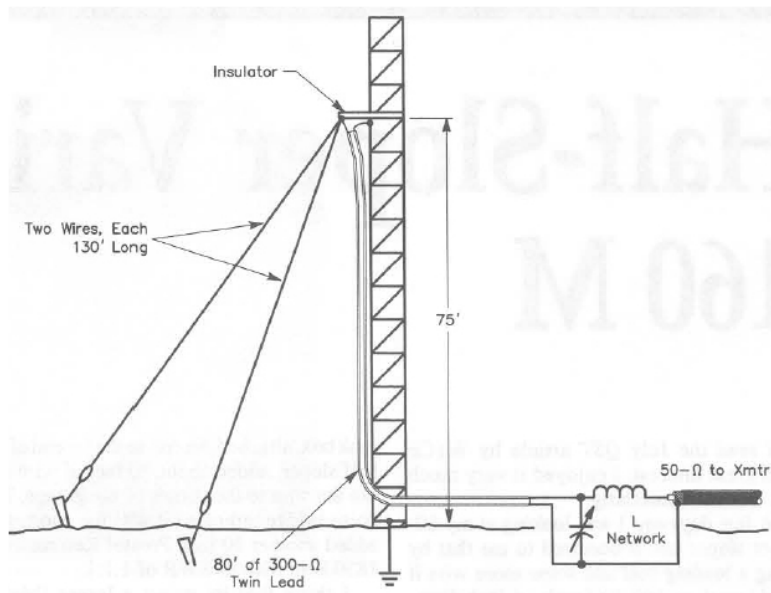

**68 - Two-Bands Half Sloper for 80m - 40m**

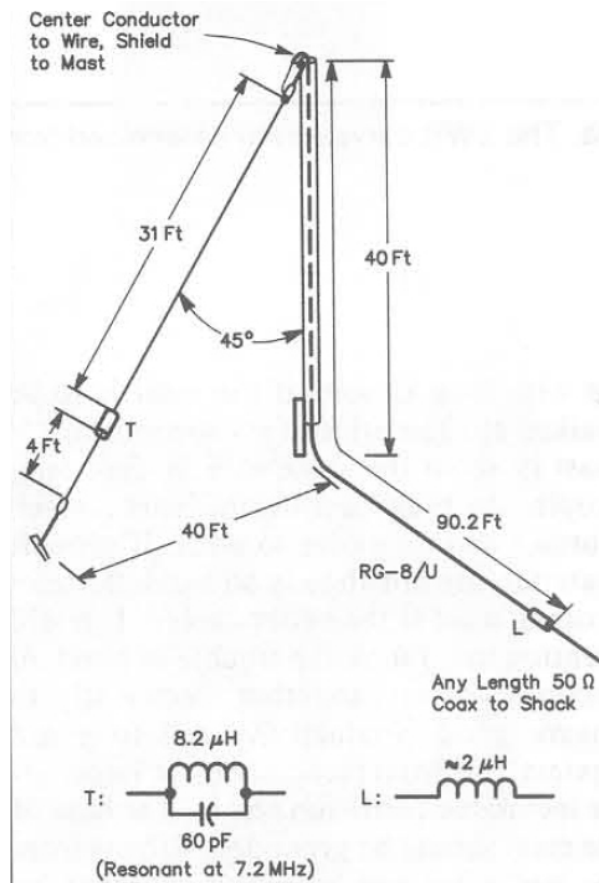

### 69 - Linear Loaded Sloper Antenna for 160m

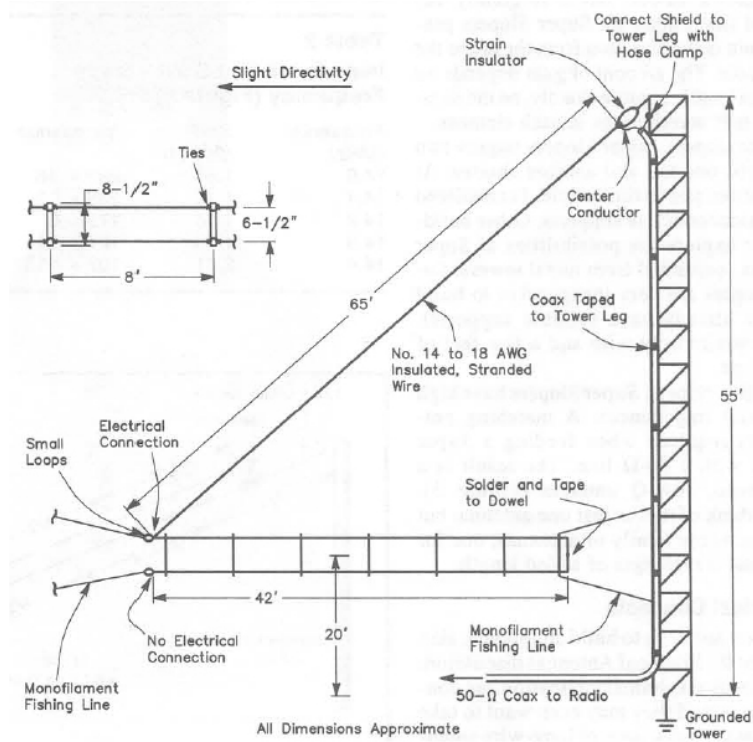

### 70 - Super-Sloper Antenna

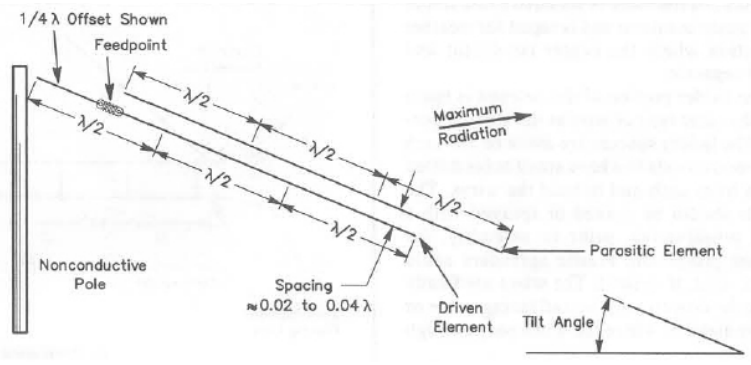

**71 - Tower Pole as a Vertical Antenna for 80m**

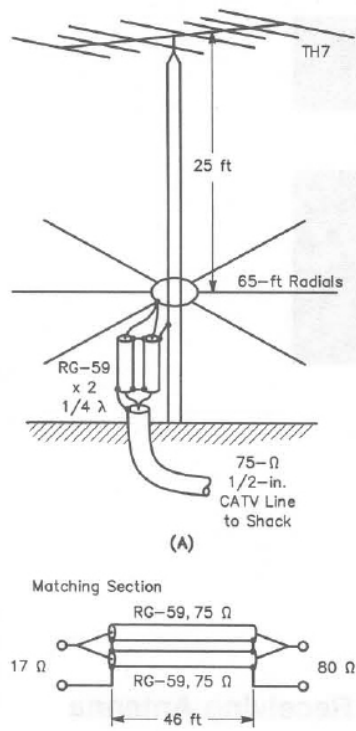

**72 - Clothesline Antenna**

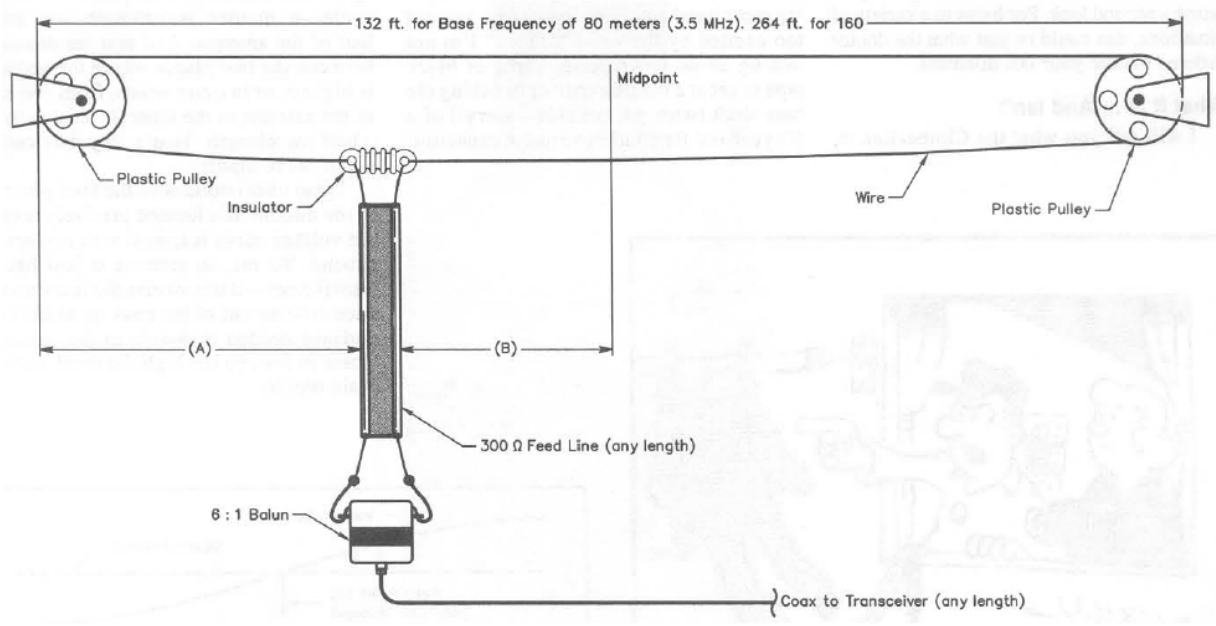

**73 - Curtain Zepp Antenna for 160m, 80m, 40m**

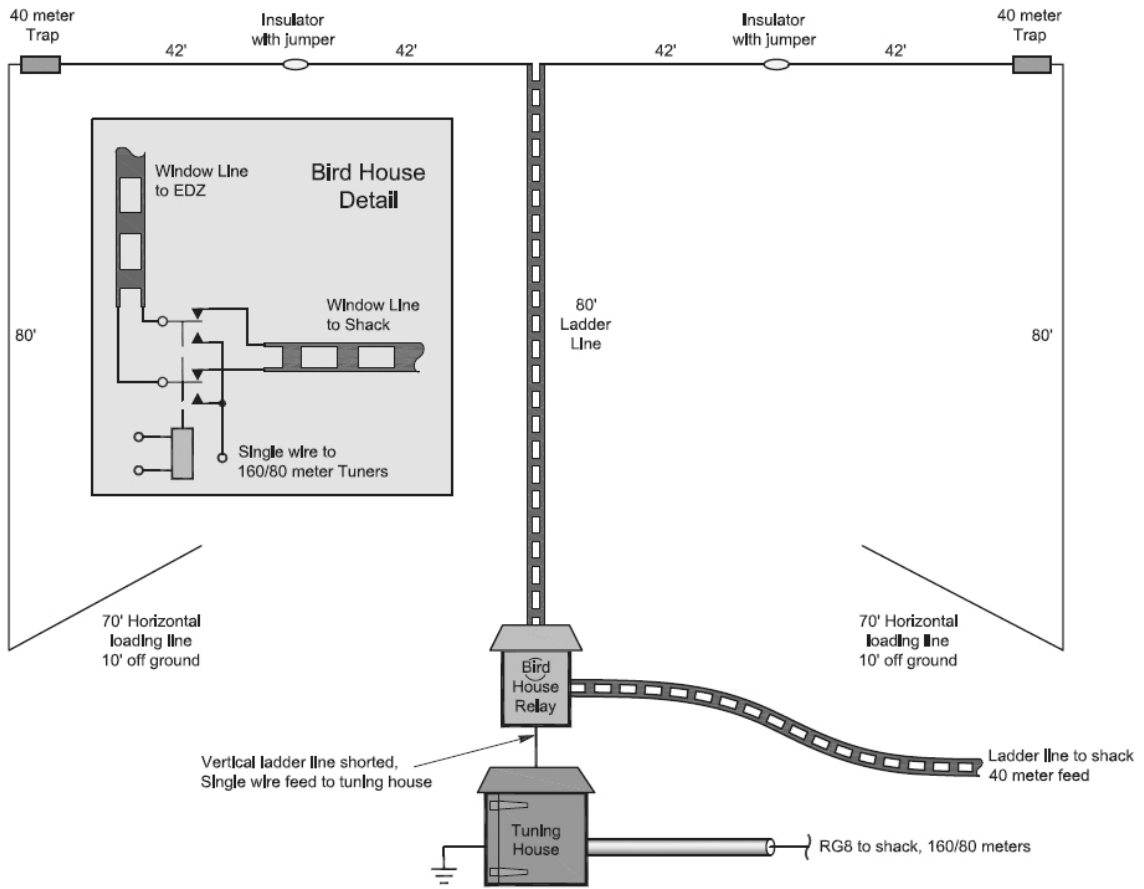

**74 - Collinear Array Antenna for 40m, 30m, 20m**

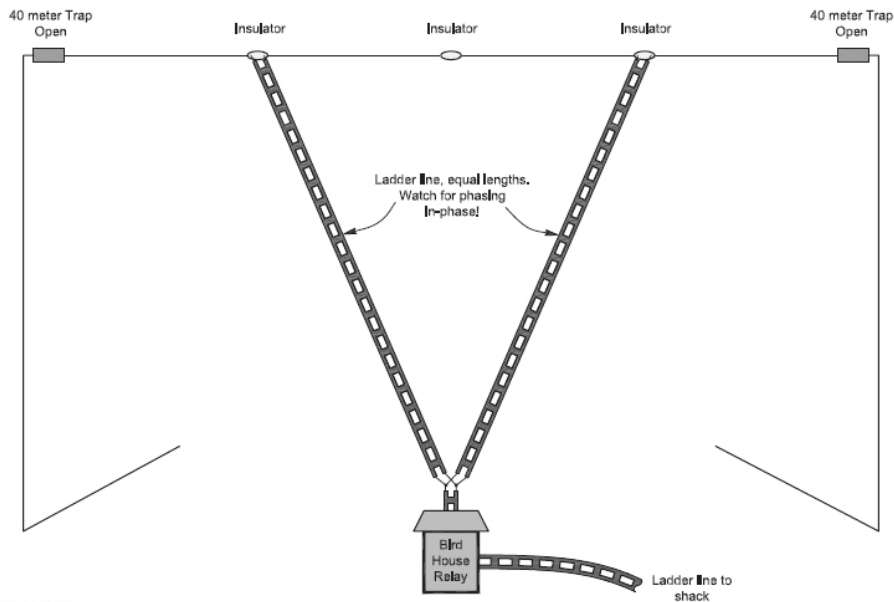

**75 - 160m Inverted Delta Loop**

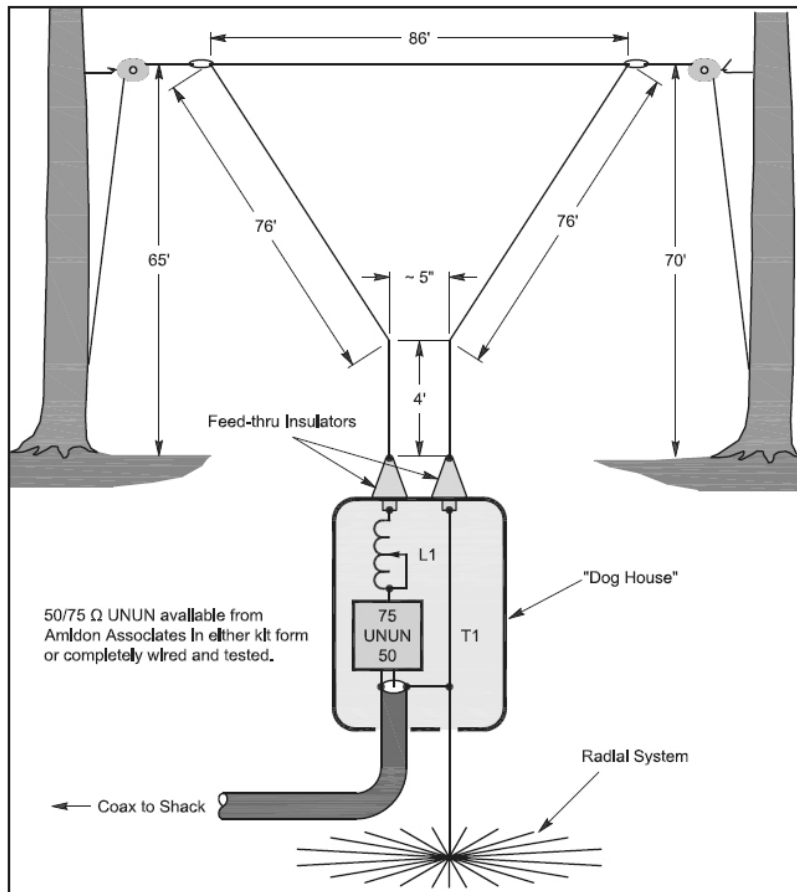

**76 - Half Rhombic Unidirectional Vertical for 20m to 6m**

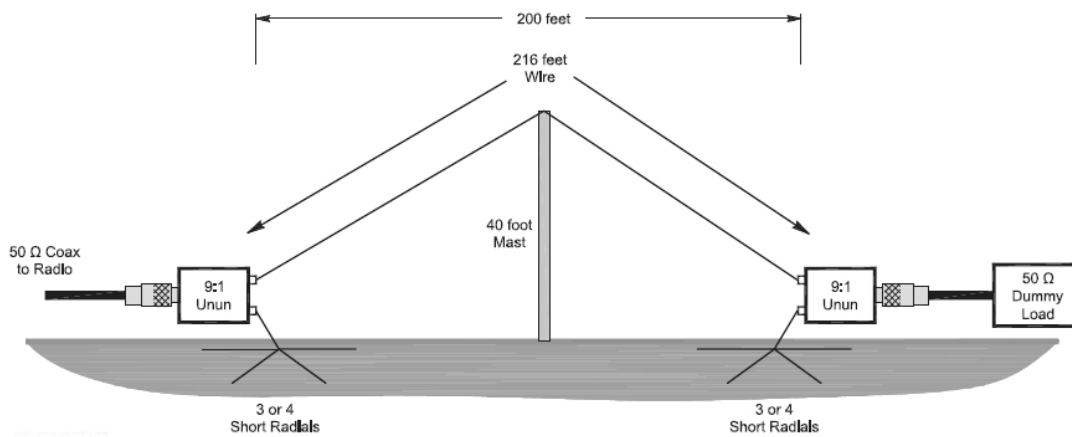

**77 - Capacitance Loaded Vertical Antenna for 160m**

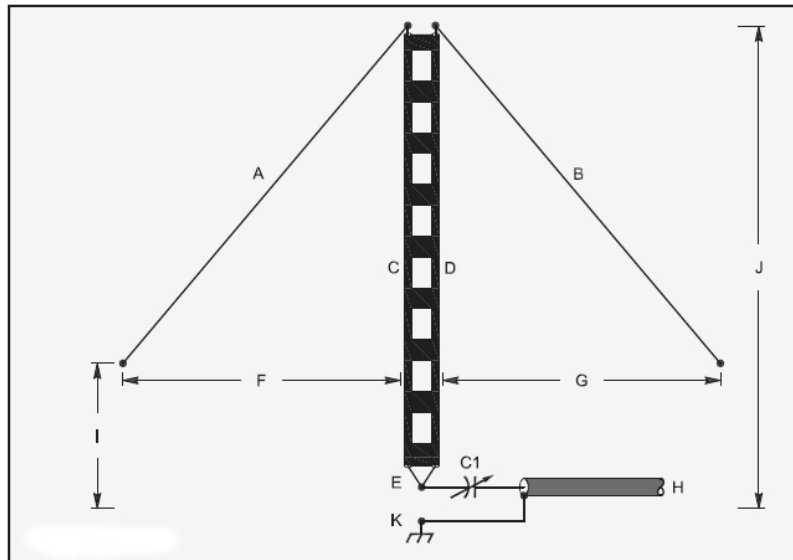

- C1 — Variable capacitor, 0-1500 pF, 7 kV.  
A, B — Sloping segments of 66 foot, 4 inch pieces of #16 AWG enameled copper wire soldered to the top of segments C and D and forming a 45° angle.  
C, D — 59 feet of 450 Ω open wire or window line or, alternatively, two parallel lengths of #16 AWG enameled copper wire with a 1 inch separation.  
E — 1 inch triangle formed by the bottom ends of the open wire line. Solder them tightly at the vertex and connect to C1.  
F, G — Distance between the lower ends of segments A and B from segments C and D, 51 feet.  
H — Any length of 50 Ω coaxial cable (RG-213 in this case). The central conductor must be soldered to C1, and the braid to the ground radials.  
I — Approximately 16 feet from ground to lower ends of sloping segments A and B.  
J — 60 feet from antenna top to bottom.  
K — Ground radials,  $60 \frac{1}{4} \lambda$  (the more the better — 32 will form a reasonable ground).

### 78 - Fan Dipole Antenna for 80m to 6m



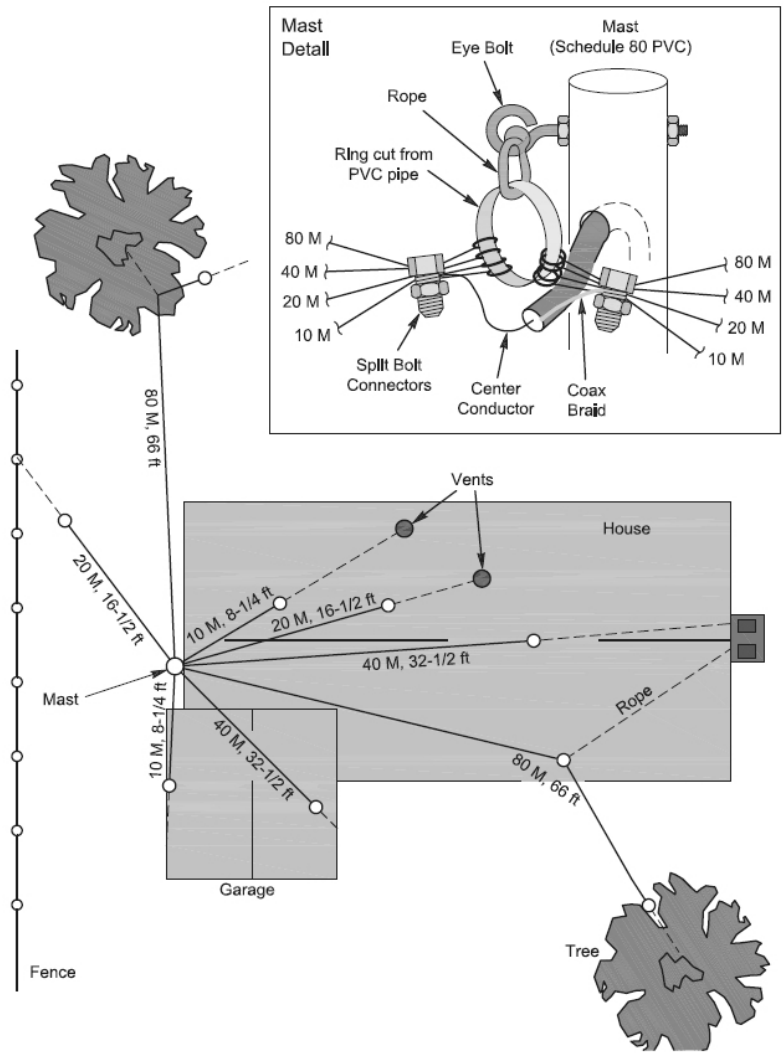

### 79 - Wire Ground Plane Antenna

The lengths of all 3 sides is determined by the formula of a 1/4 wave antenna  
This antenna configuration will work for all frequencies from 160 meters to VHF.

$$\text{Length (in feet)} = \frac{234}{\text{frequency in MHz}}$$

The vertical side uses the inner conductor of the coax. On the Budwig the is the side the shows a "+" (plus sign). The outer (lower) legs use the outer braid or the "-" (minus sign).

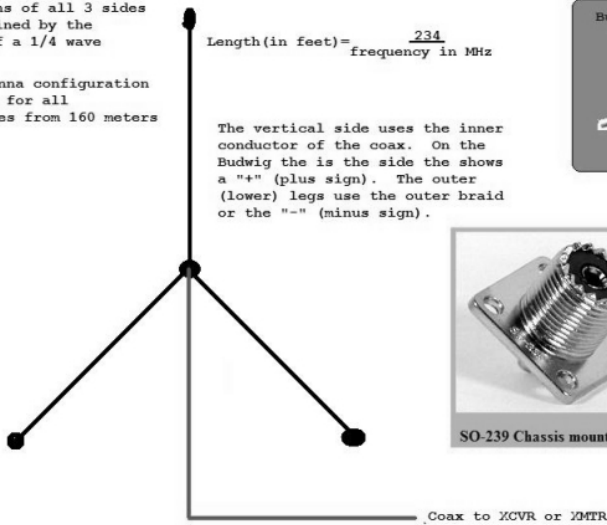
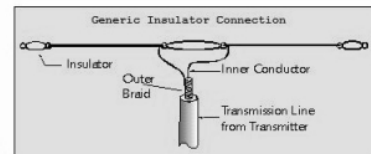
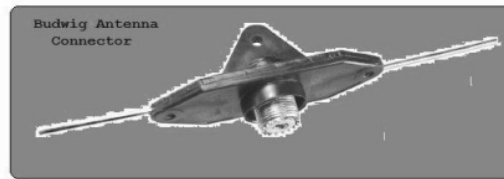

### 80 - Inverted Delta Loop Antenna for 160m

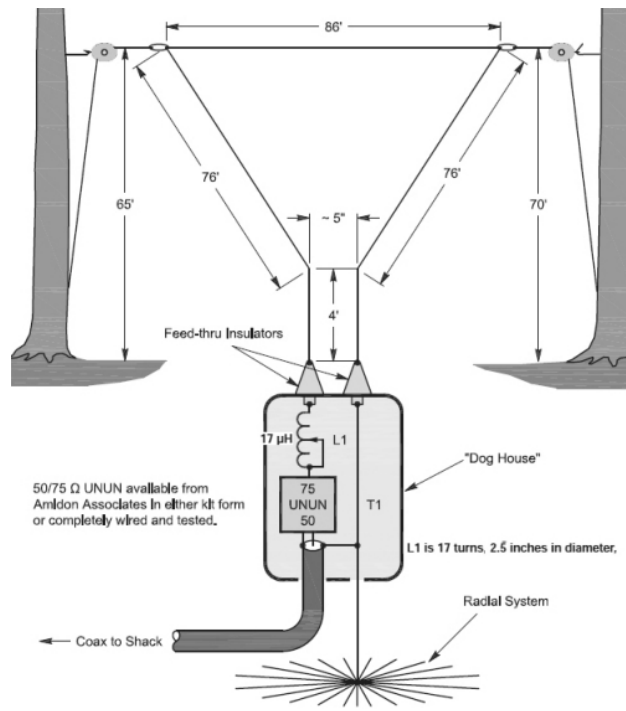

**81 - Inverted-L for 160m**

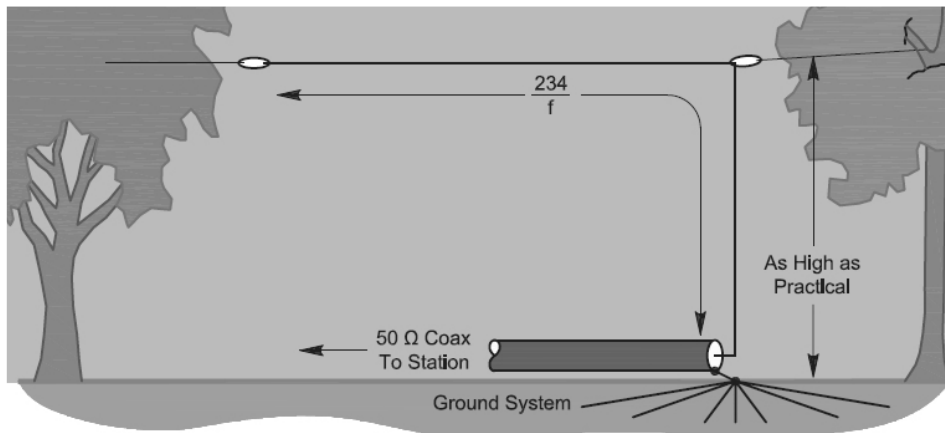

**82 - 300ohm-Ribbon Dual Band Dipole**

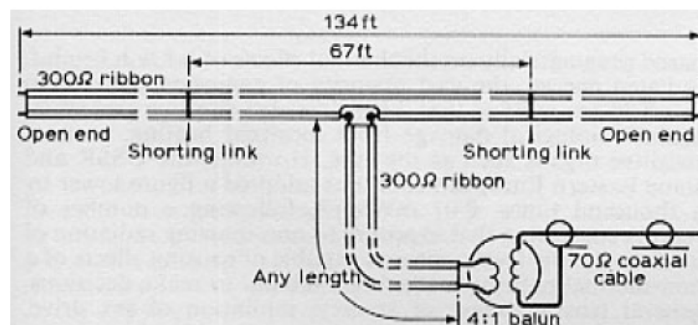

**83 - Tri-Band Beam for 20m, 15m, 10m**

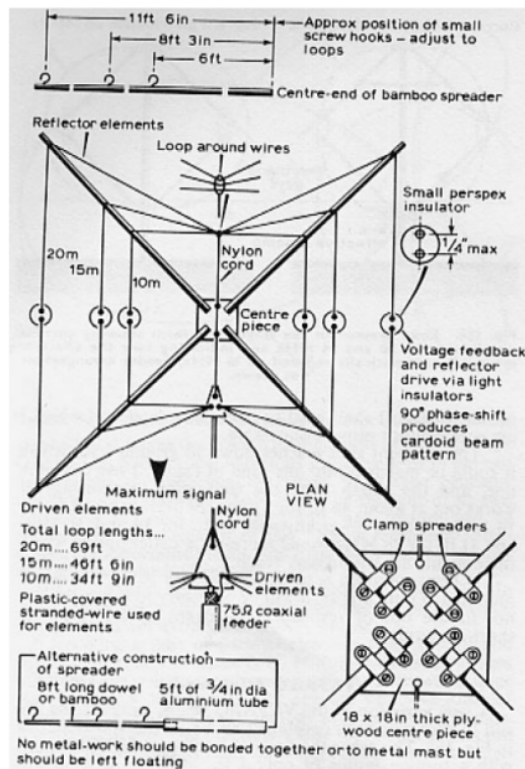

### 84 - Mini-Horse Yagi Antenna

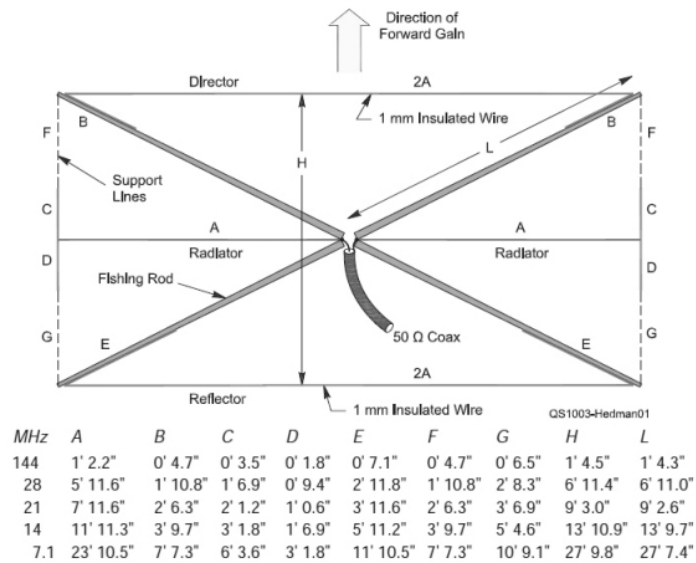

### 85 - Half-Rhombic Directive Antenna for 20m to 6m

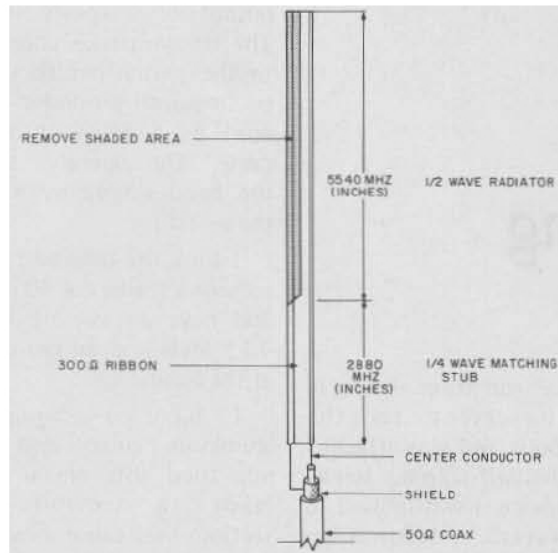

Frequency (MHz)	28.0	28.5	29.0	50.0	51.0	52.0	144	145	146	147
Radiator (inches) 1/2 wave	197.8	194.3	191.0	110.8	108.6	106.5	38.4	38.2	37.9	37.7
Stub (inches) 1/4 wave	102.8	101.0	99.3	57.6	56.4	55.3	20.0	19.8	19.7	19.6

### 86 - Fan-Dipole Antenna for 80m to 6m

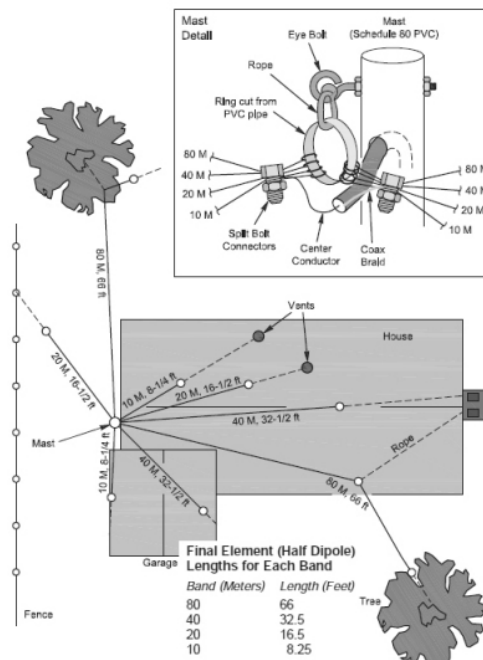

### 87 - Capacity Tuned Folded Loop Antenna for 20m

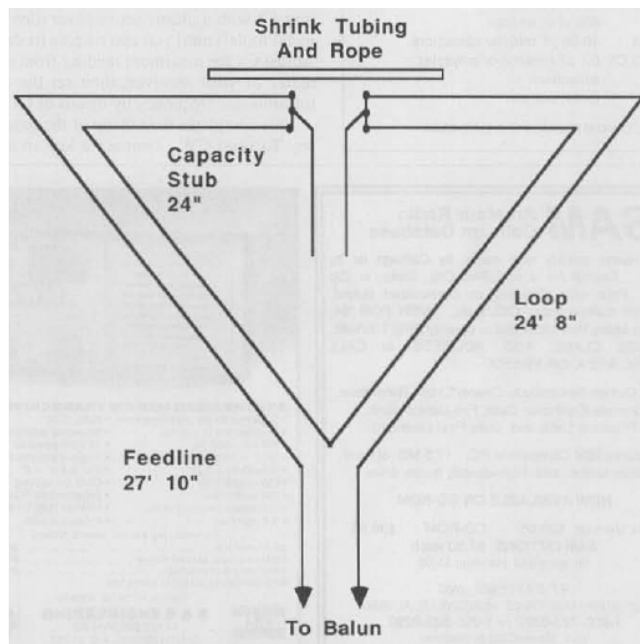

**88 - Indoor Loop Antenna for 80m to 30m**

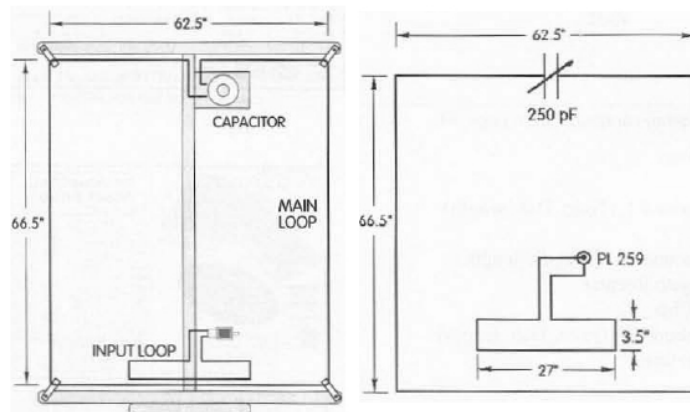

**89 - Indoor Loop Antenna for 80m**

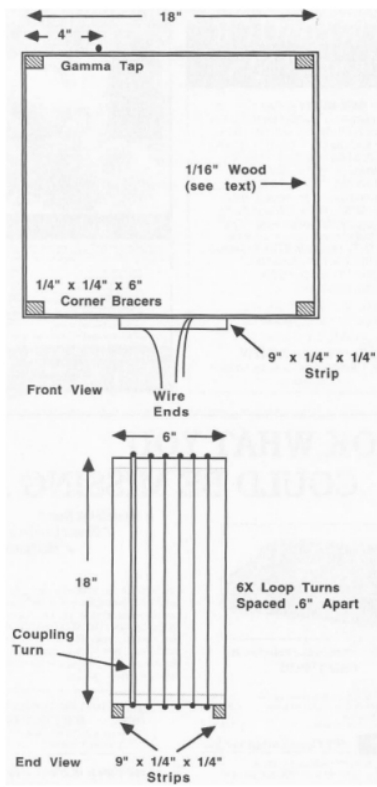

**90 - Double-Delta Antenna 80m and 40m**

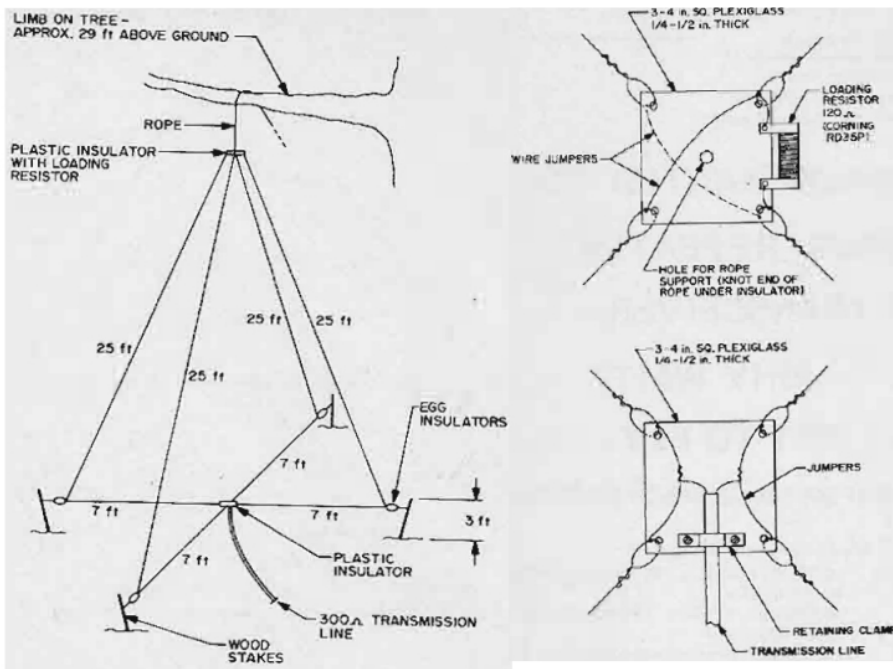

**91 - Inductance-Loaded Shortened Dipole for 160m**

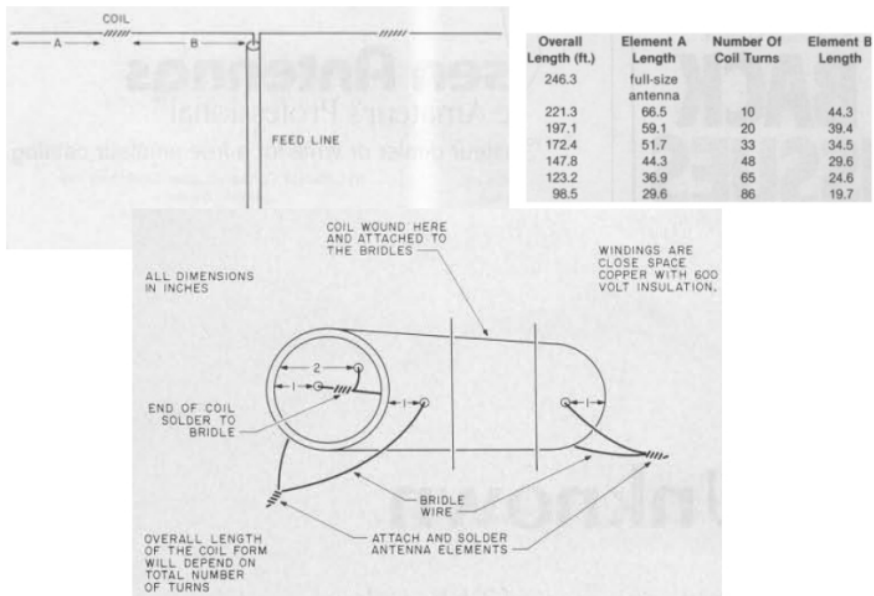

### 92 - V-Beam Antenna for 15m

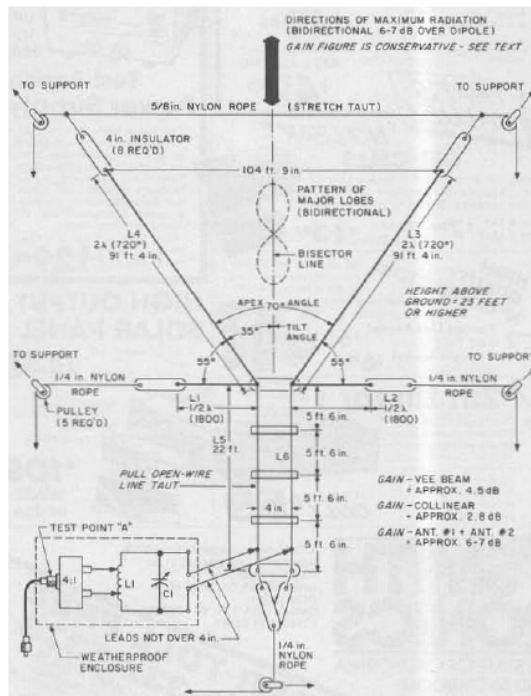

### 93 - Picnic Vertical Wire Antenna

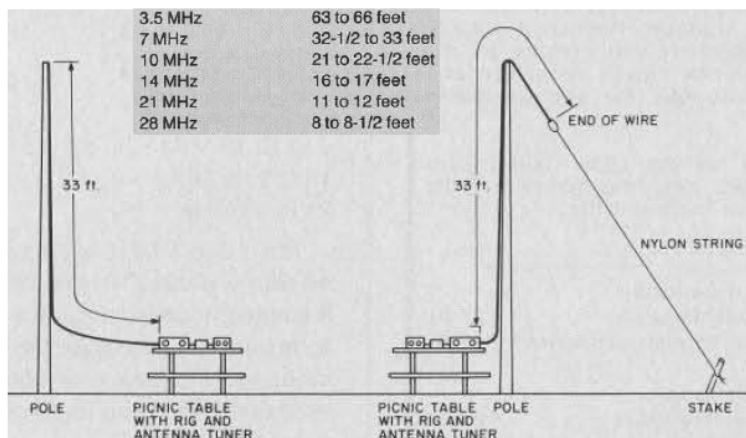

### 94 - Laid-Back Quad Antenna for 80m

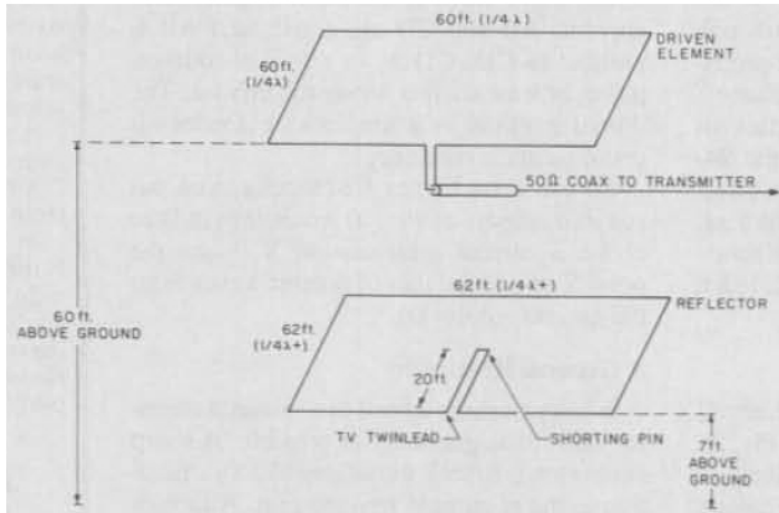

### 95 - Phased Loop Antenna

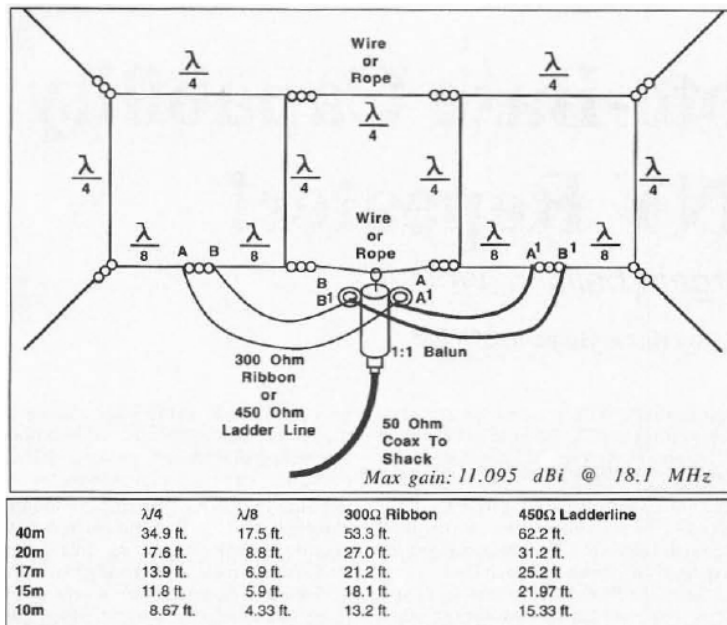

### 96 - Loop Antenna for TX for 160m

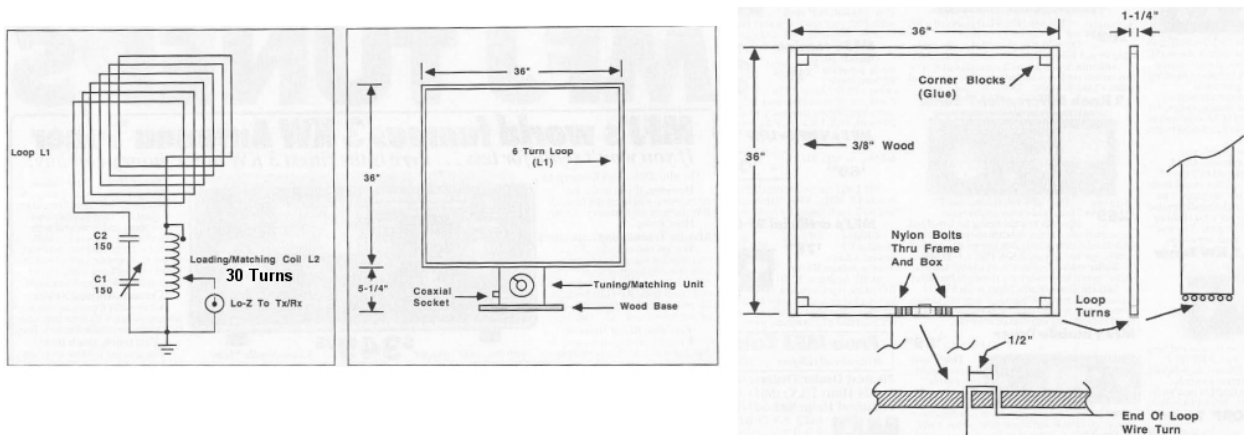

### 97 - Morgain-Dipole Antenna for 160m and 80m



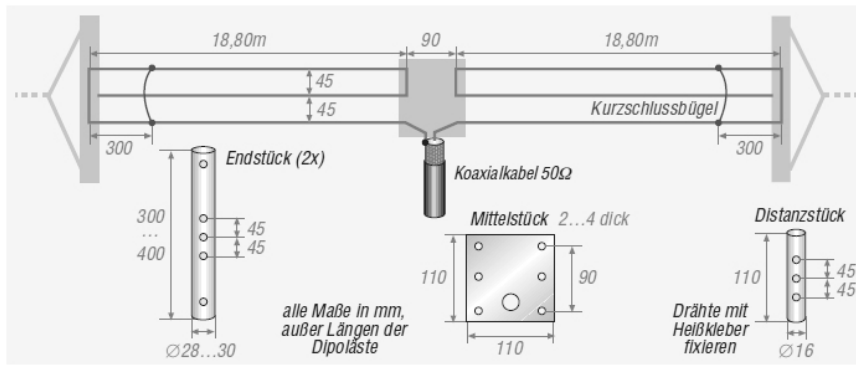

98 - ZL-Special for 20m, 15m, 10m

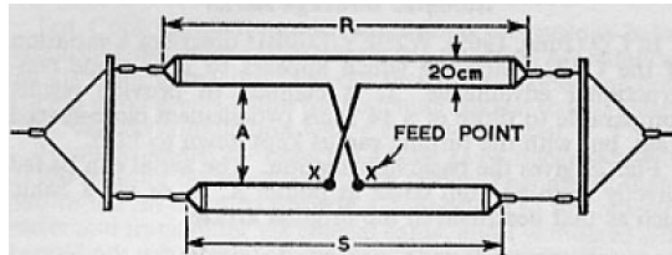

	S	R	A	A
28 Mc/s	5.09m 4.17m	5.39m 4.42m	1.29m 1.06m	$\frac{1}{2}\lambda$ $\frac{1}{10}\lambda$
21 Mc/s	6.85m 5.62m	7.24m 5.94m	1.72m 1.41m	$\frac{1}{2}\lambda$ $\frac{1}{10}\lambda$
14 Mc/s	10.30m 8.45m	10.85m 8.90m	2.58m 2.12m	$\frac{1}{2}\lambda$ $\frac{1}{10}\lambda$

99 - Biconical Antenna

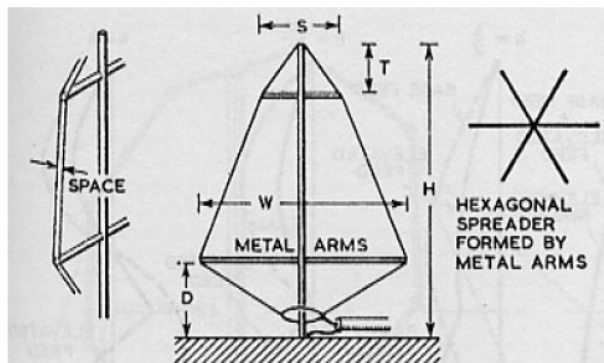

	H	W	D	T	S	SPACE	WIRE
3.5 - 15 Mc/s	43'	17'-8"	16'-10"	2'-2"	5'-10"	3"	NR 8
7 - 28 Mc/s	23'	9'-6"	9'	12"	3'-2"	2"	NR 10
14 - 56 Mc/s	12'	5'	4'-9"	8"	1'-8"	1"	NR 12

100 - Directive Delta-Birdcage Antenna for 20m to 10m

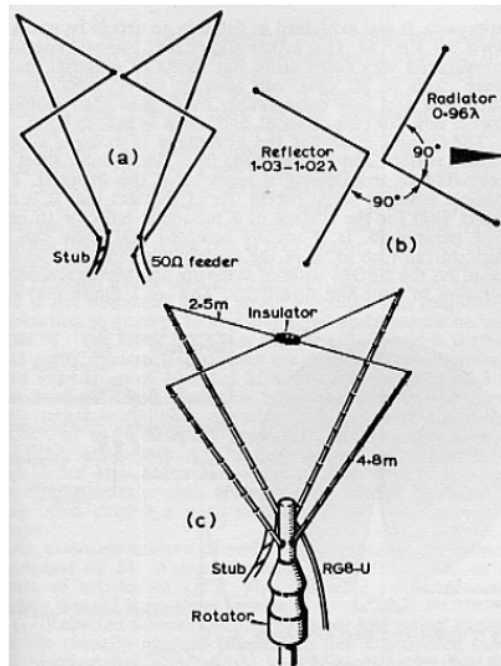

101 - Dual Polarization Antenna for 80m and 40m

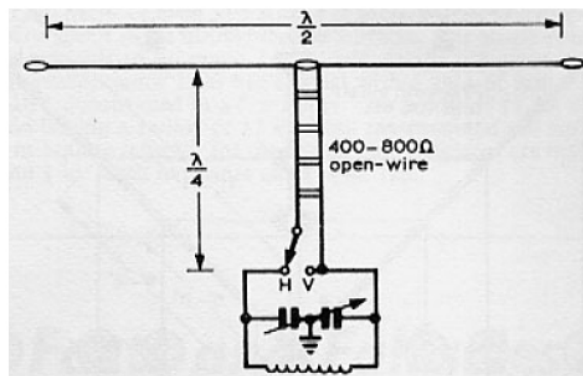

102 - Directive 300-ohm-Ribbon Folded Dipole for 15m

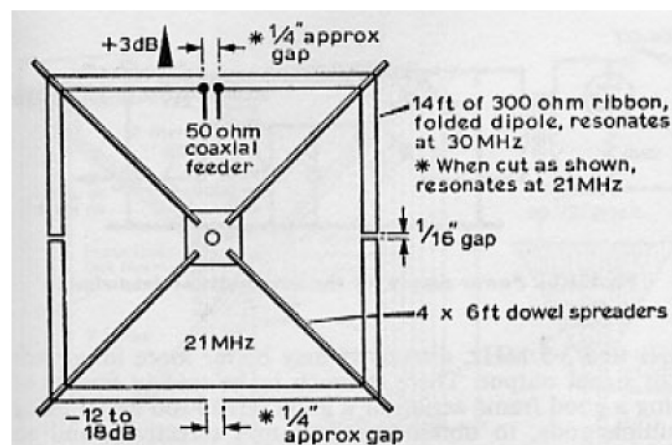

103 - Miniature Directive Antenna for 10m

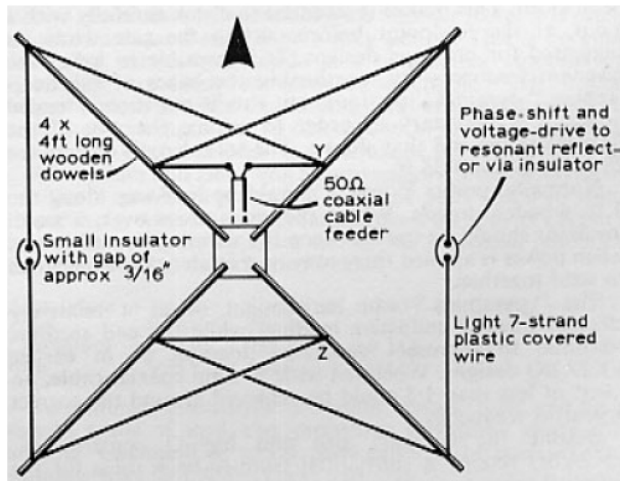

**104 - Biquad Antenna 12dBi-Gain for 2.4GHz**

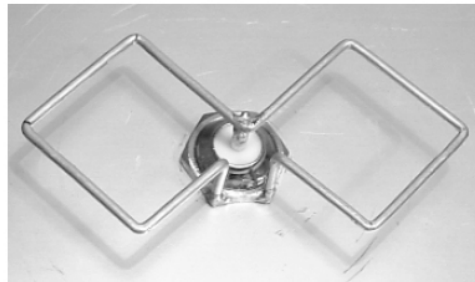
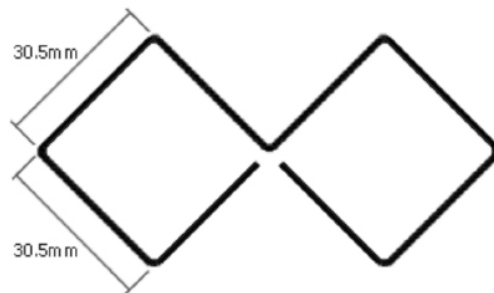

**105 - Dual-Rhomboid Antenna for 435MHz to 870MHz**

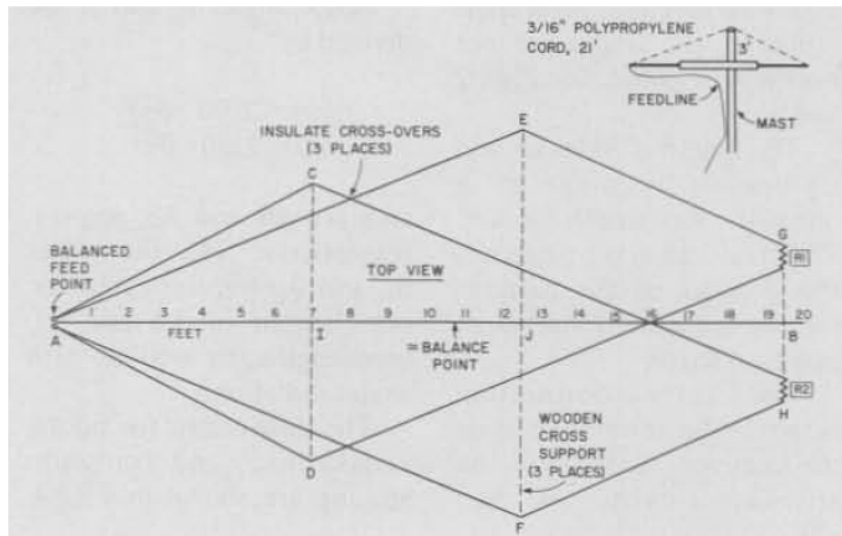

Dual rhomboid antenna for 435-870 MHz. Beamwidth  $\approx 10^\circ$  H x  $6^\circ$  V. Gain over DP  $\approx 26$  dB. Boom length: AB = 19'6". Support spacing: AI = 7'; IJ = 5'6"; JB = 7'. Support length: CD = 7'3"; EF = 10'3"; GH = 3'0". Rhomboid sides: AC, AD, EG, FH = 7'9.5"; AE, AF, CH, DG = 13'5.5". Feedline: 3/16" Polypropylene Cord, 21'. Wire needed: 14 AWG formvar,  $\approx 86'0"$ . Boom material: AI, JB = wood; IJ = metal. Cross support: CD, EF, GH = wood. Terminators: R1, R2 = 600 Ohms; Watts

**106 - Double-Bazooka Antenna for 80m**

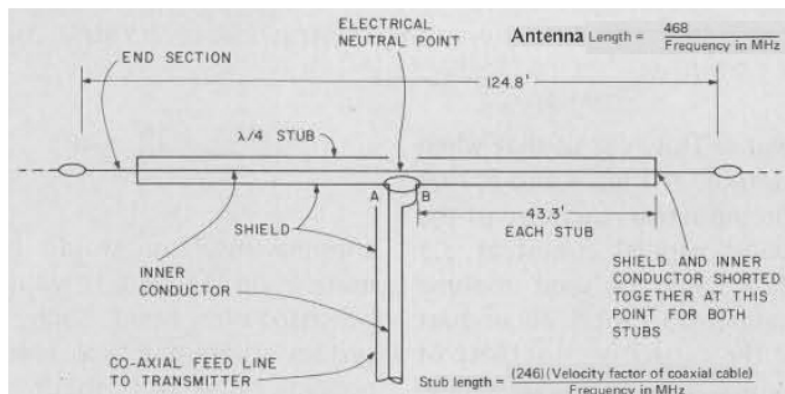

**107 - J-Style Antenna**

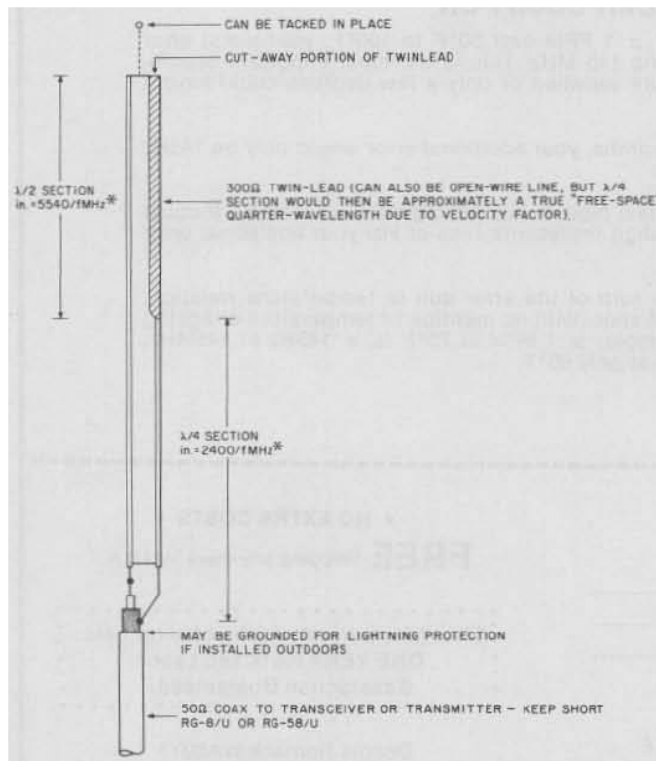

**108 - Vertical / Horizontal / Circular Polarization Antenna**

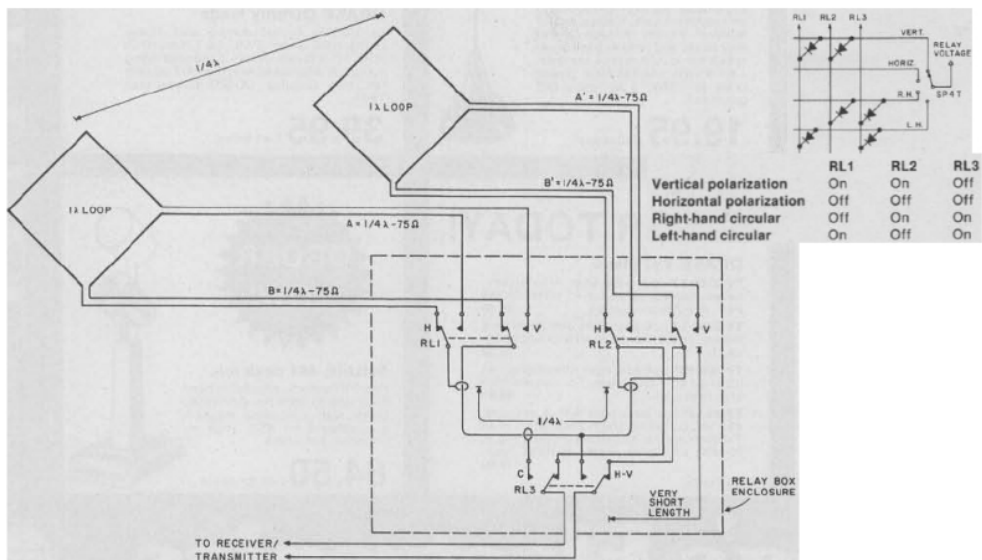

**109 - Coax Inverted-L Antenna for 80m**

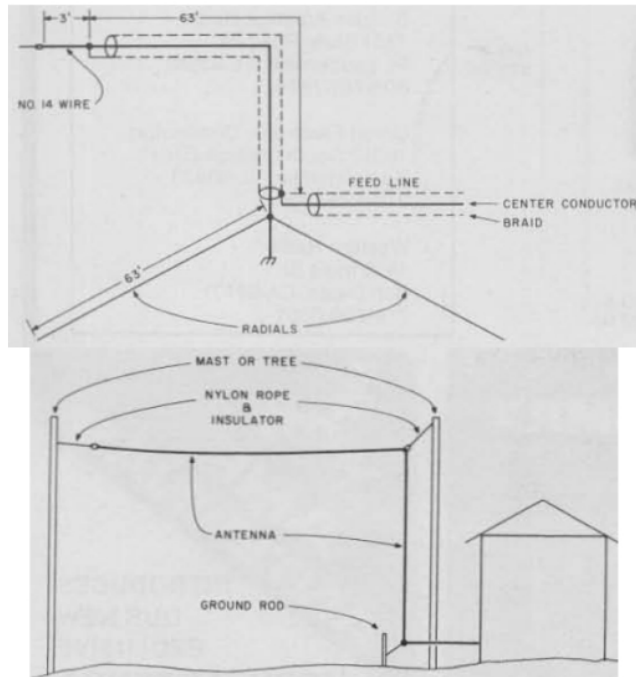

110 - Indoor Compact Loop Antenna for 80m

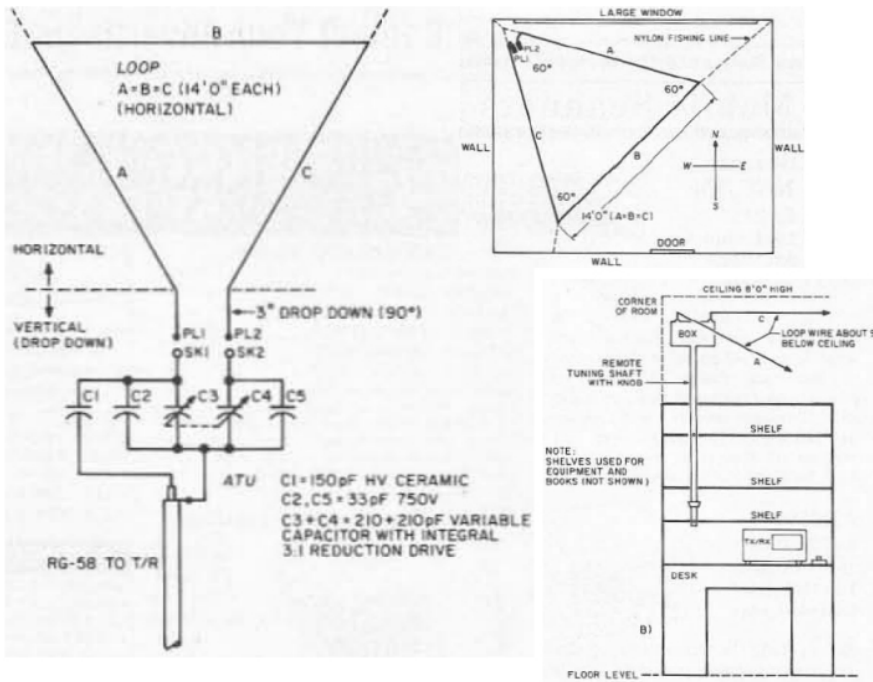

111 - Helix Antenna

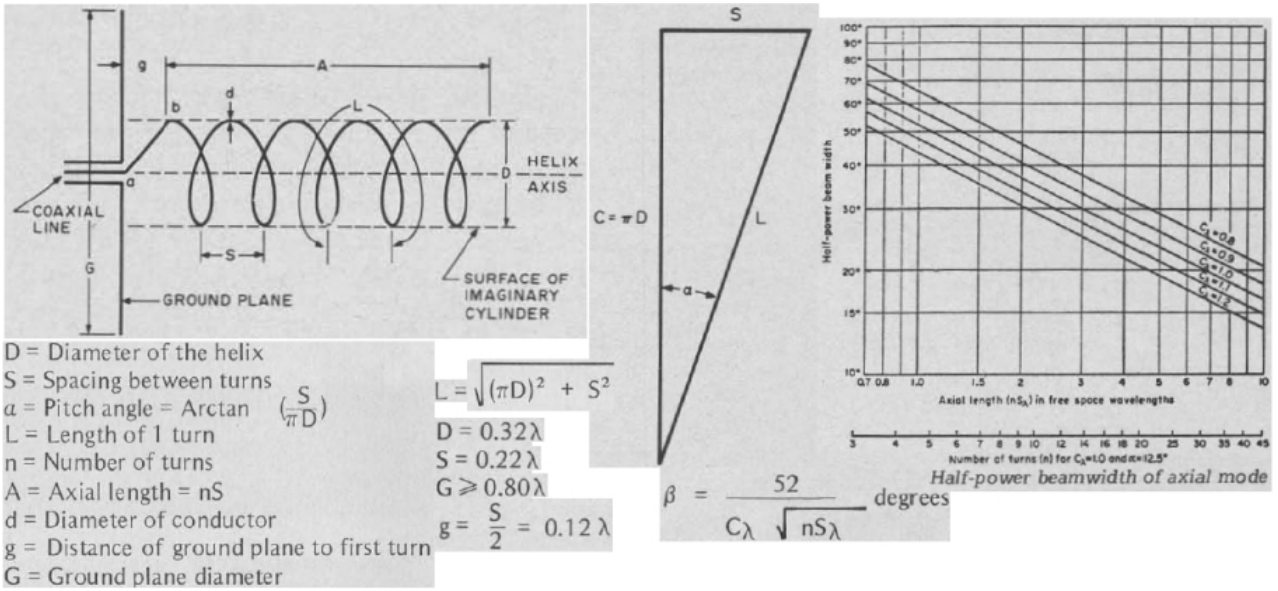

112 - Novice Vertical Antenna for 80m, 40m, 15m, 10m

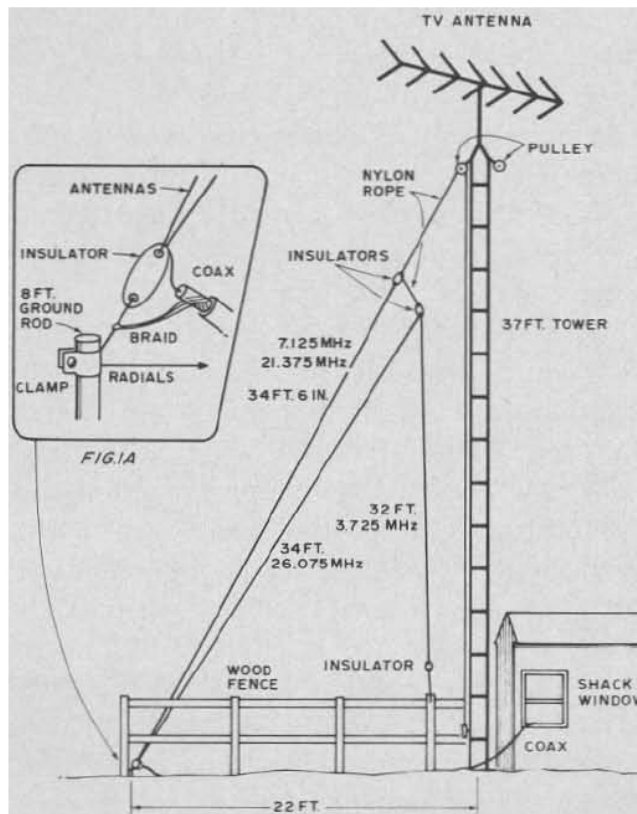

113 - Stub-Loaded Shortened Dipole for 80m

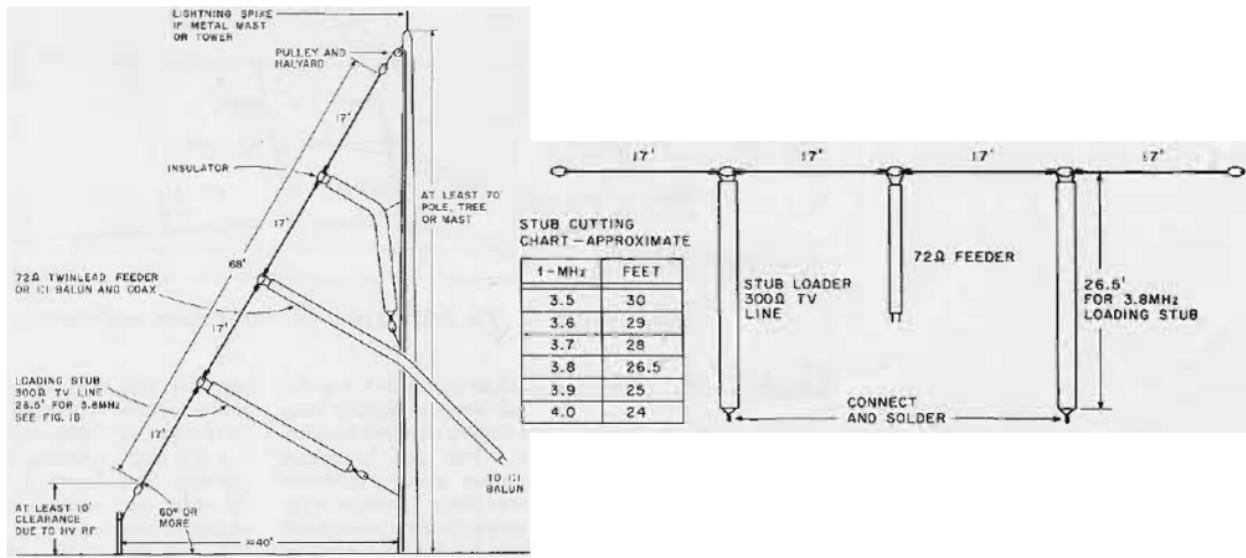

**114 - Six-Band Wire-Stub Trap Antenna for 40m-10m**

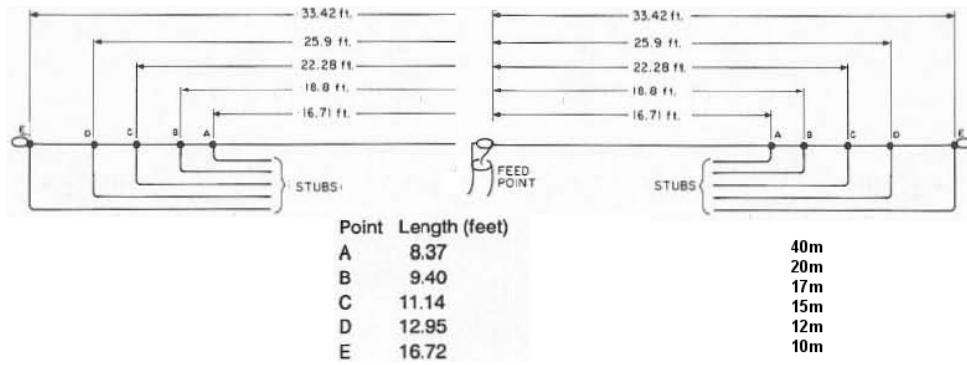

**115 - Multiband Half-Wave Delta-Loop Antenna**

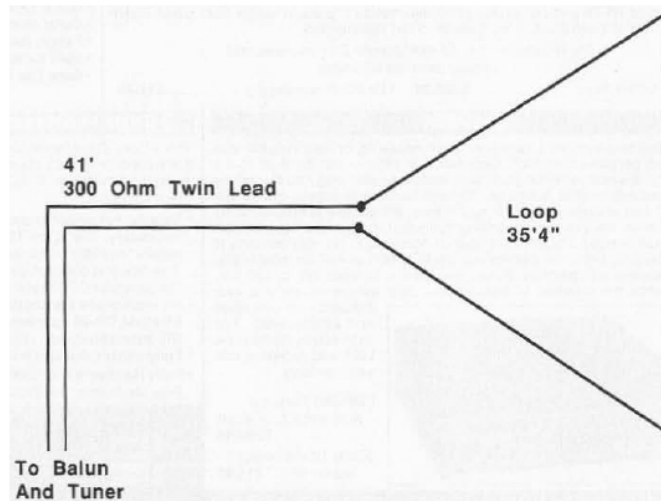

**116 - Hybrid Vee for 20m, 17m**



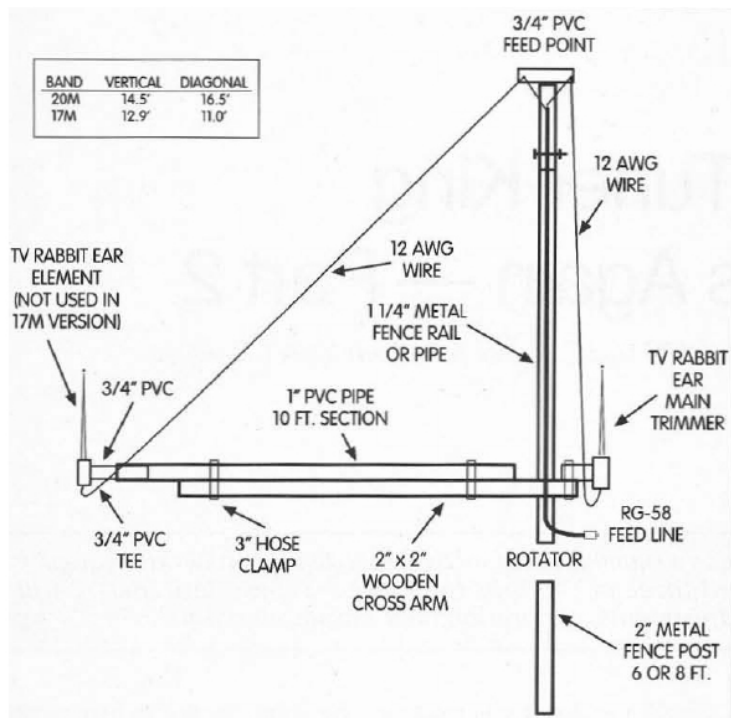

**117 - Six-Shooter Array Antenna, Gain=7.5dB**

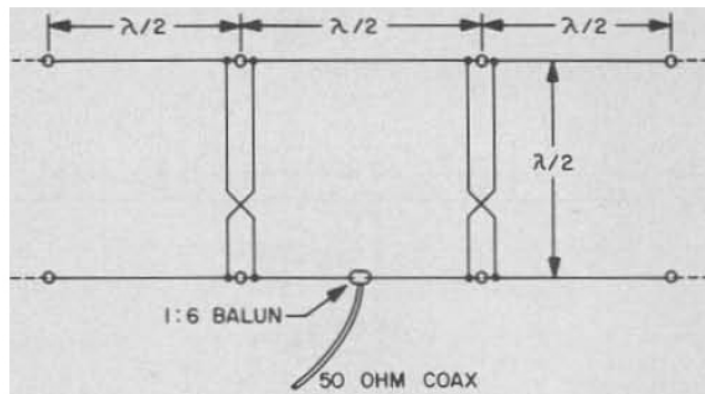

**118 - Multiband Ground-Plane Antenna for 10m, 15m, 20m**

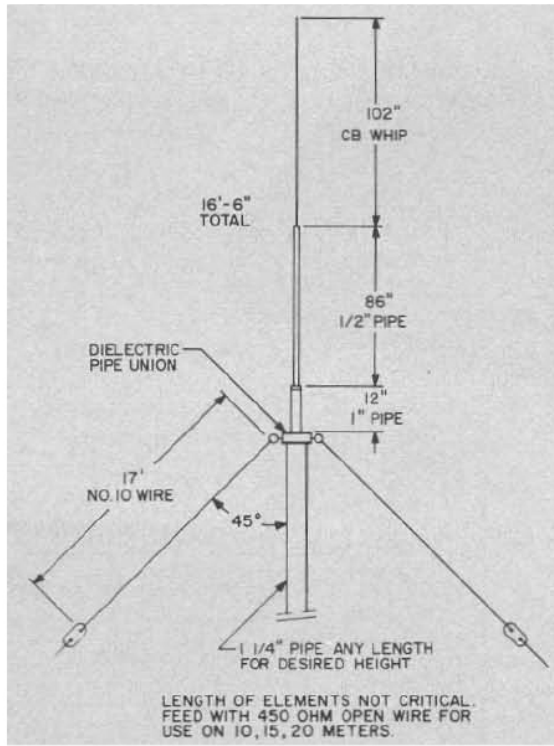

**119 - Wire Superbeam Antenna for 10m, 15m, 20m**

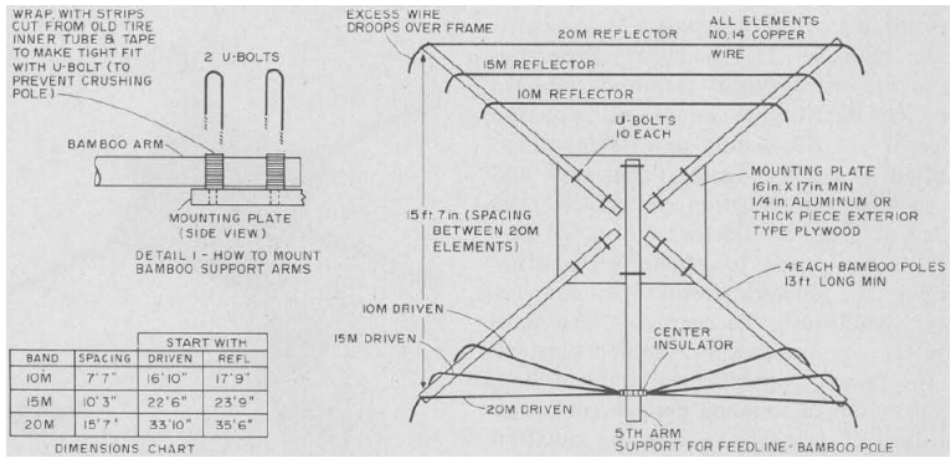

**120 - Two Elements Delta-Loop Antenna**

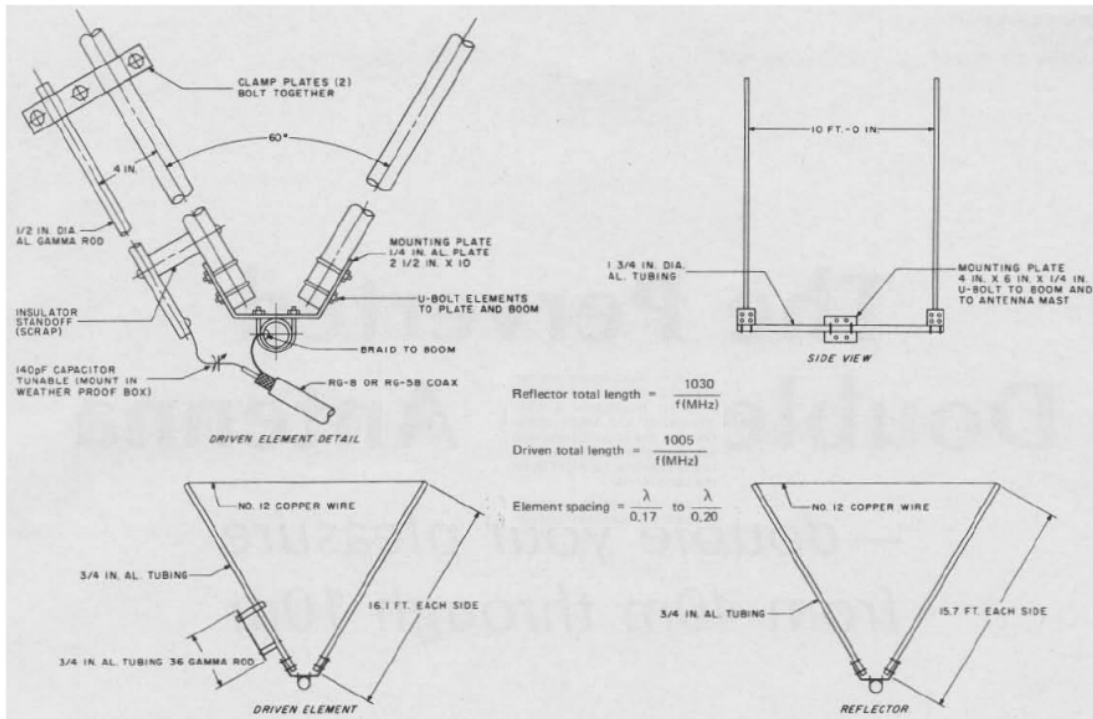

121 - Sterba Curtain Antenna

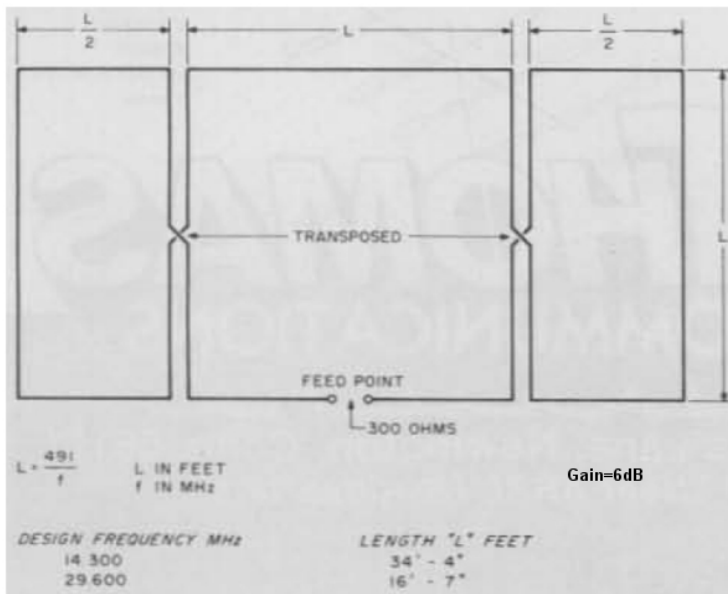

122 - Half-Wave Vertical Zepp Antenna

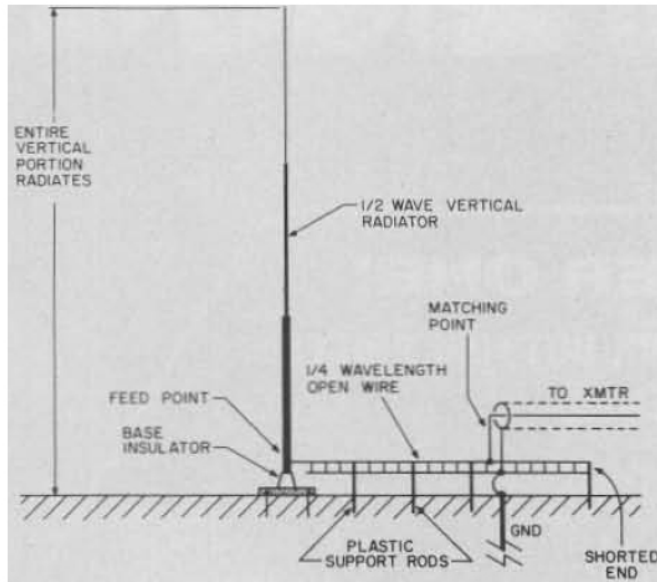

123 - Lazy-Loop Antenna for 40m

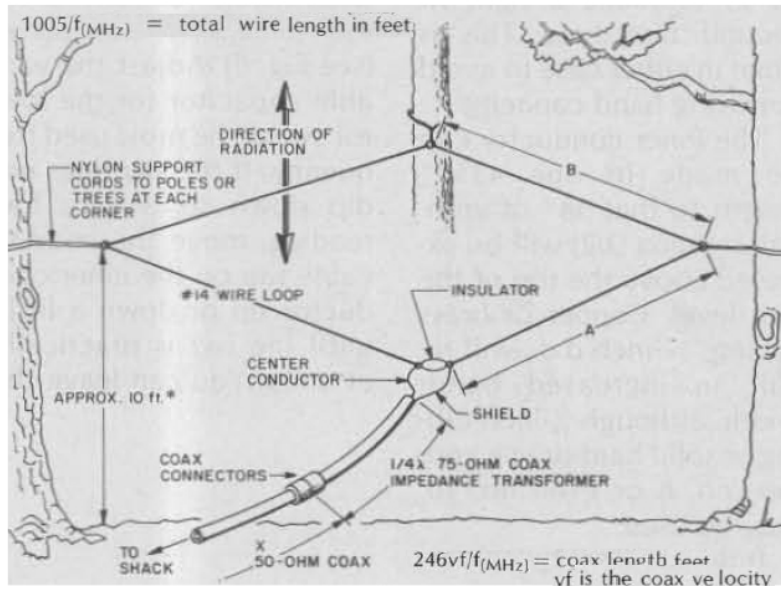

124 - Terminated Folded Dipole for 80m, 40m

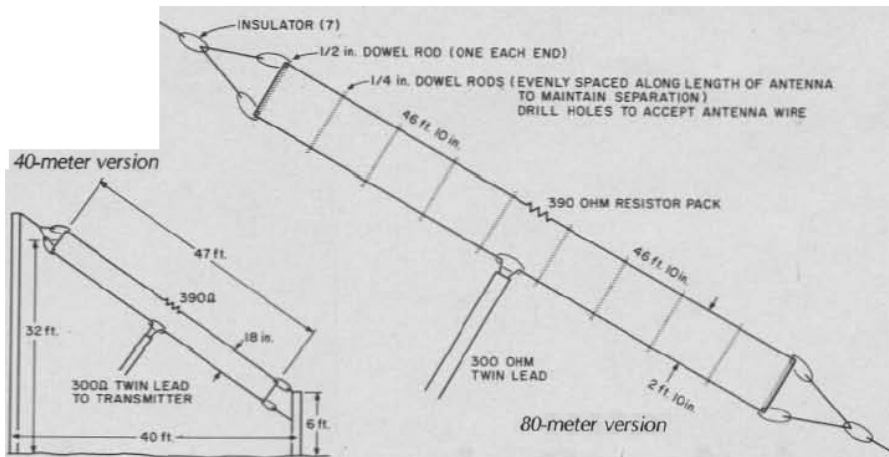

125 - Short-Fat Antenna for 15m

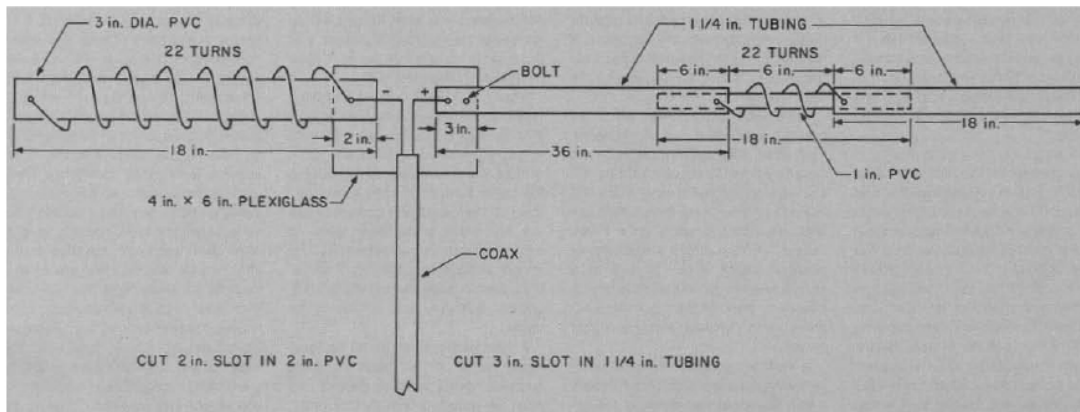

126 - Cobra Antenna for 80m

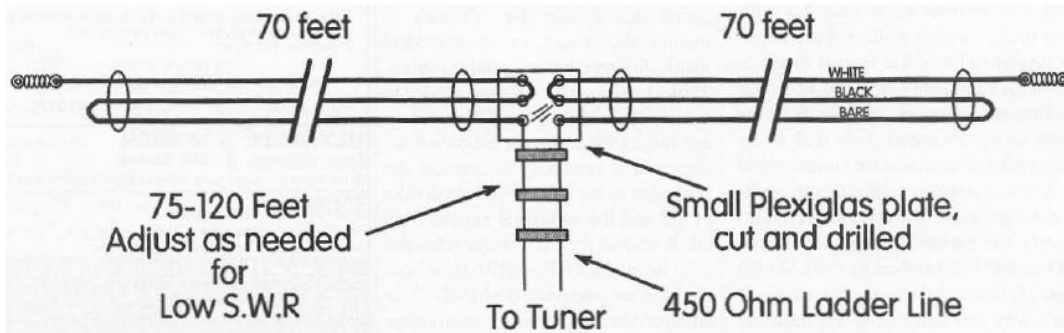

127 - Log-Periodic Wire Antenna for 20m, 15m, 10m

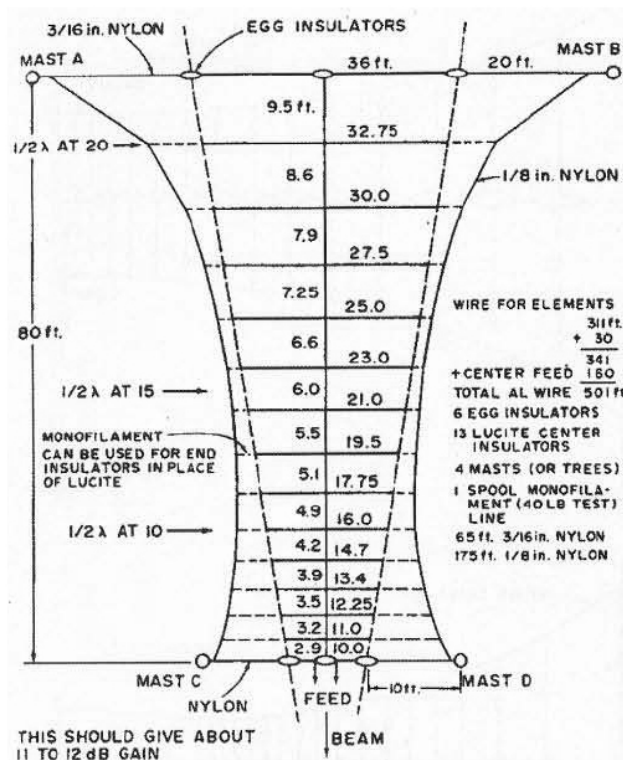

128 - 5-Element Log-Periodic Vertical Antenna for 80m, 40m, 20m

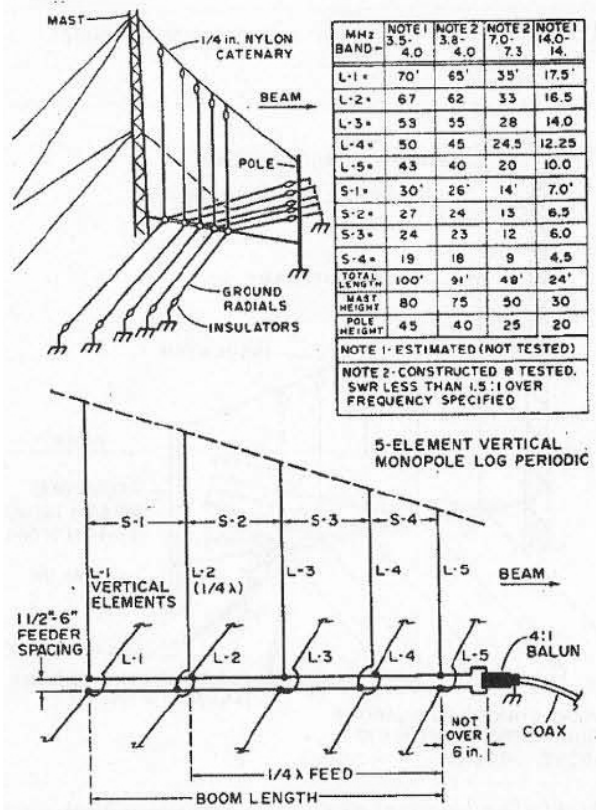

**129 - 2m Vertical Wire Antennas**

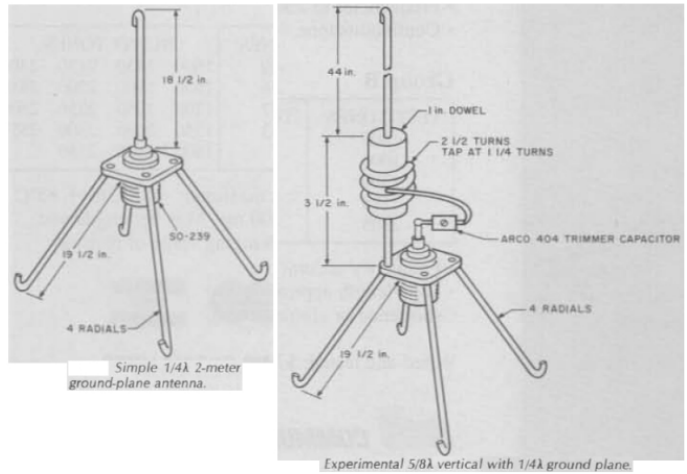

**130 - Earth-Mover Inverted-V Antenna for 40m**

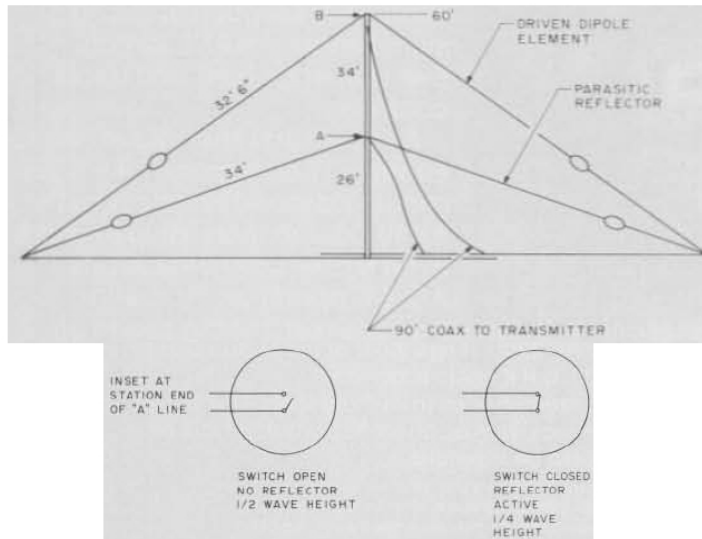

**131 - Coax-Cable Collinear Antennas**

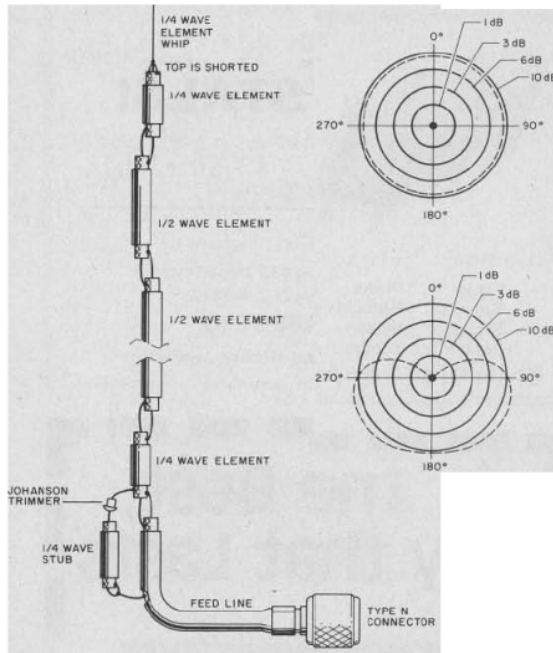

8 elements = 6 dB. 16 elements = 9 dB

**132 - Double Bobtail Antenna for 20m**

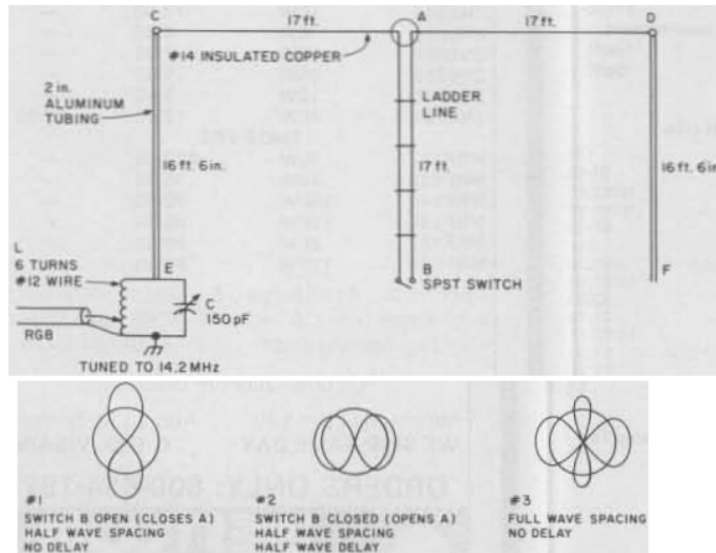

### 133 - Collinear Zepp Antenna

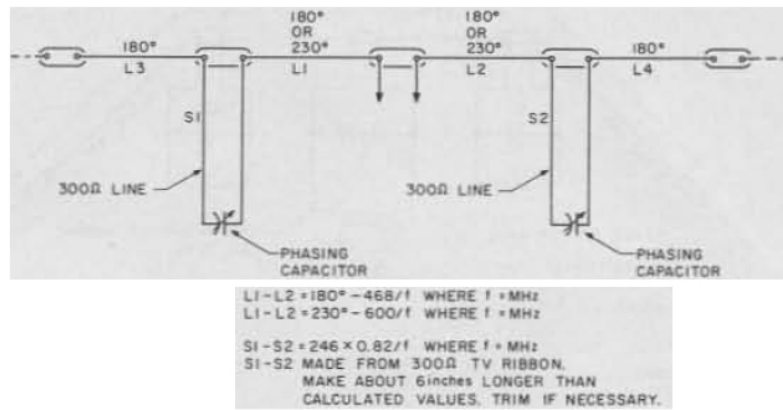

### 134 - Taylor Vee Antenna for 20m

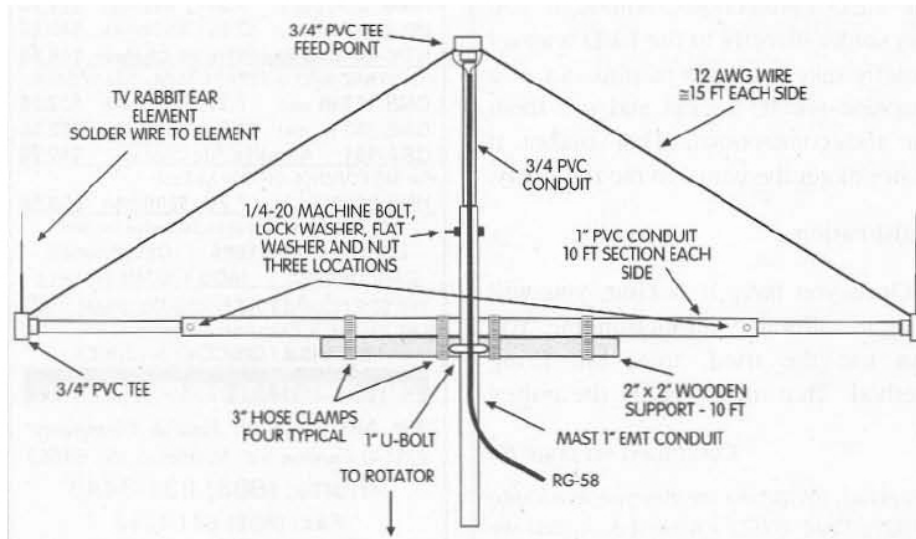

### 135 - Collinear Vertical Antenna 6dB-Gain for 2m, 1.3m, 73cm



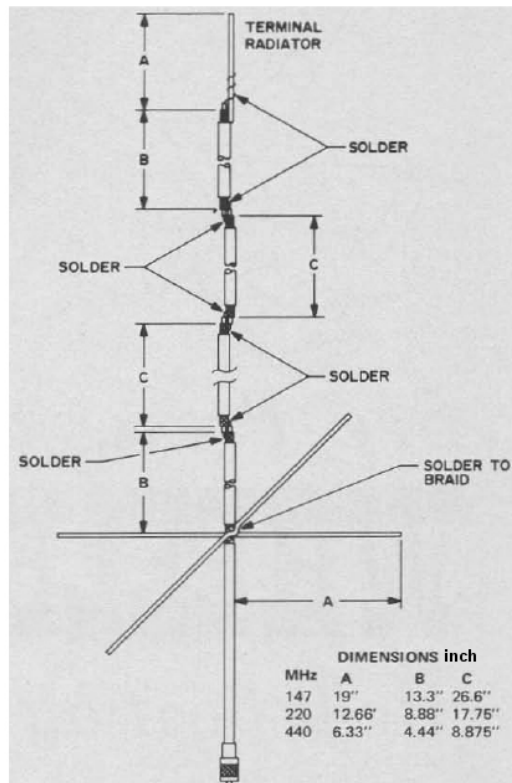

136 - Bi-Loop Antenna for 20m

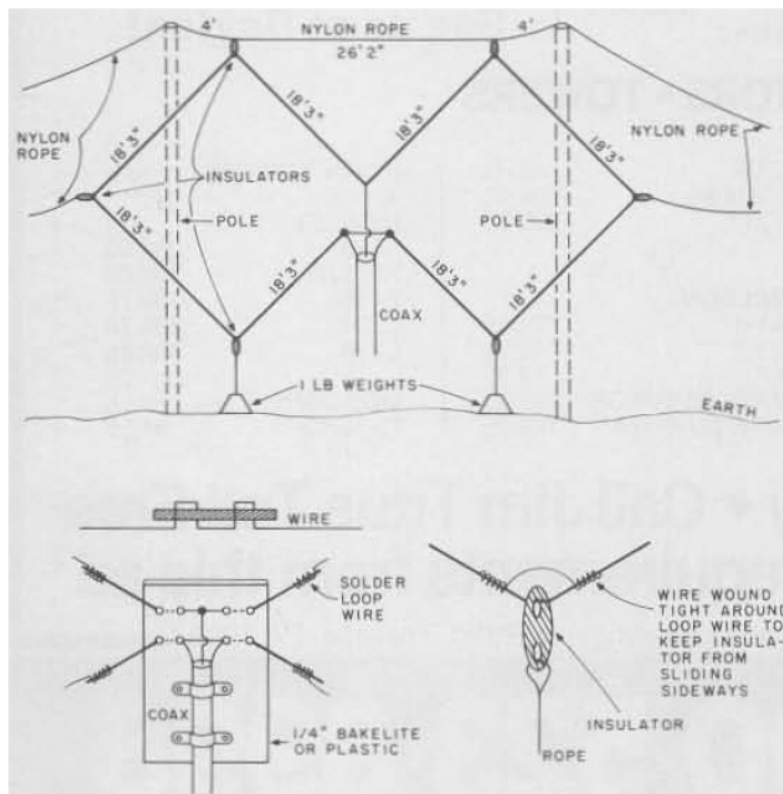

137 - Wire Beam 6dBd-Gain for 10m

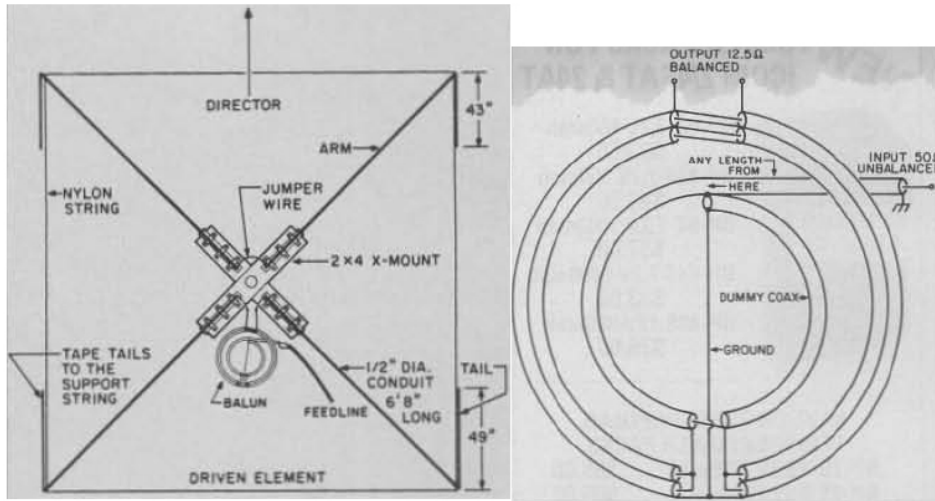

**138 - Sloping Diamond Antenna 4dB-Gain for 40m**

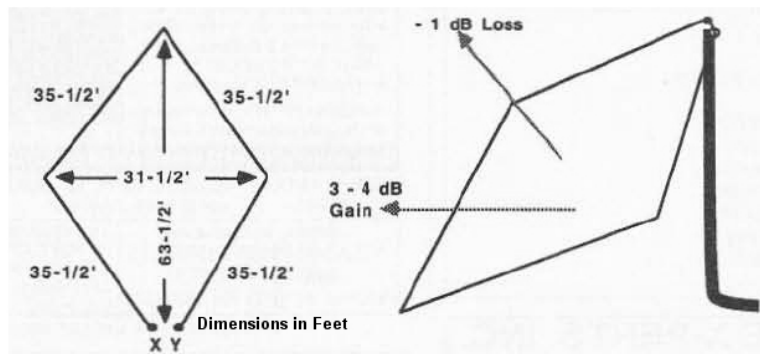

**139 - Twisted Loop Antenna for 160m**

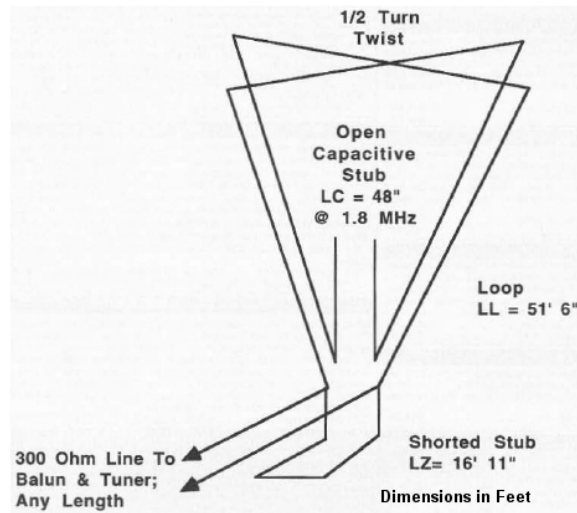

**140 - DX RX Loop Antenna for 160m**

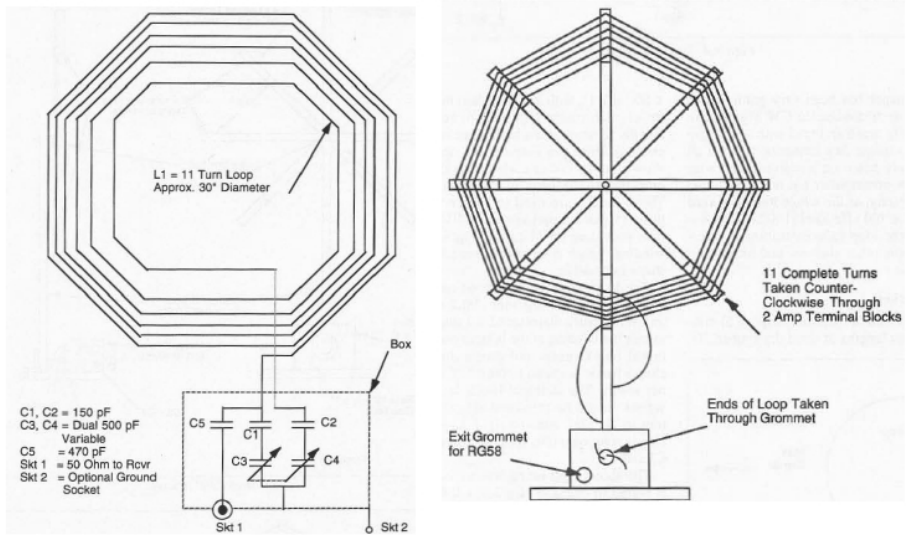

**141 - Hentenna 3dB-Gain for 10m, 6m, 2m**

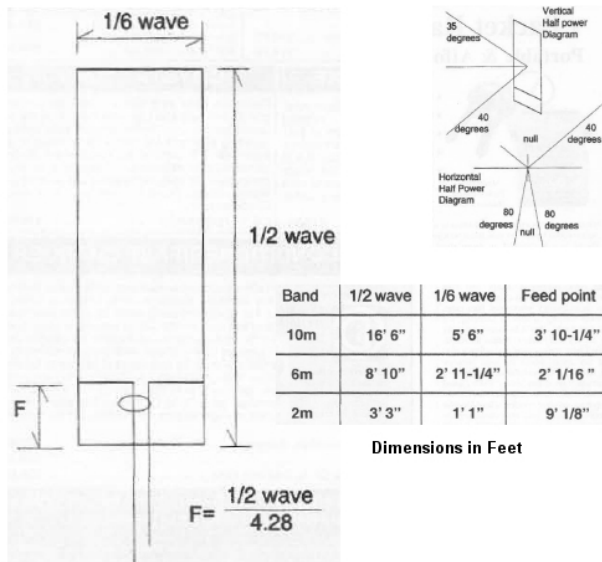

**142 - VK2AAR Wire Antenna for 20m**

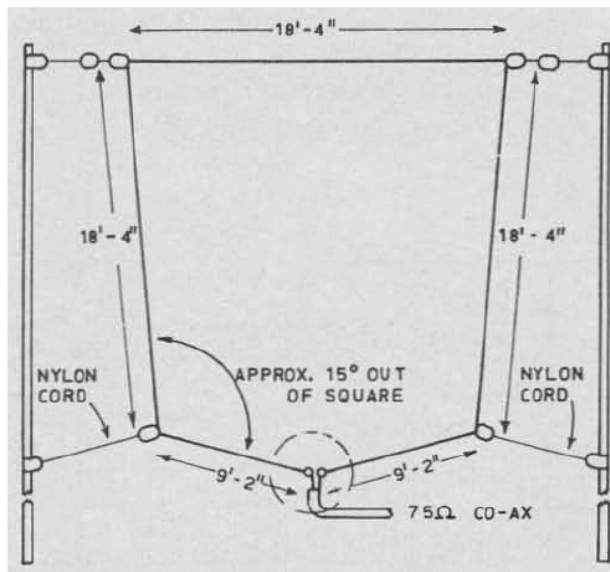

**143 - 2-Elements Quad Antenna for 6m**

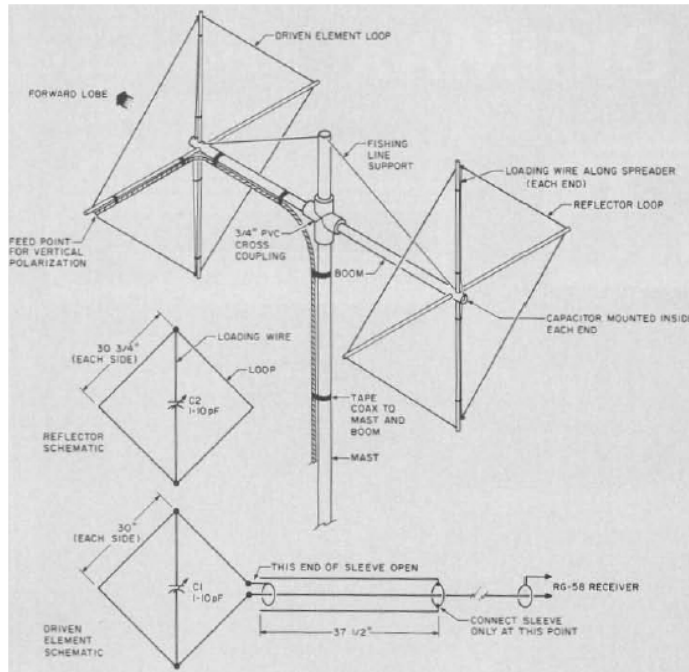

**144 - Hula-Loop Bidirectional 6dB-Gain Antenna for 17m**

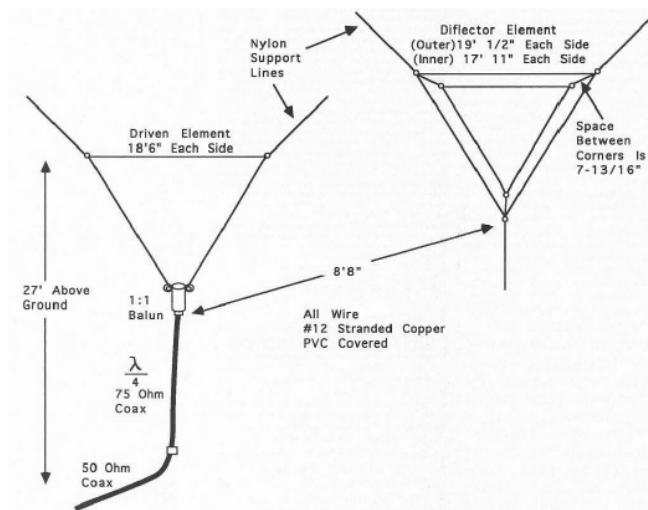

**145 - Moxon Rectangle Beam for 15m-10m**

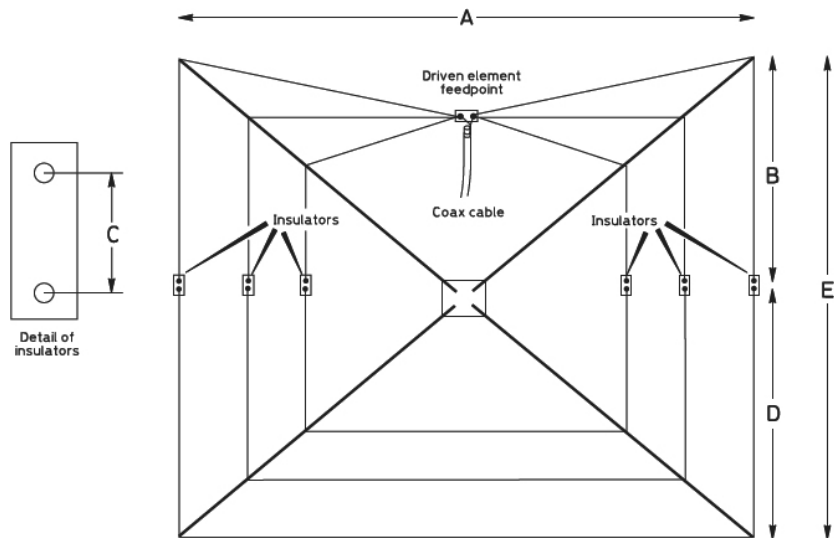

$A = 98.26/f = (m); 322/f = (ft)$        $56.09/f = \text{length of diagonal in metres}$   
 $E = 53.96/f = (m); 177/f = (ft)$        $184/f = \text{diagonal length in ft.}$   
 $C = 560\text{mm (22in) for 14MHz, 380mm (15in) for 21MHz and 250mm (10in) for 28MHz}$

### 146 - Double-D Beam 4dB-Gain

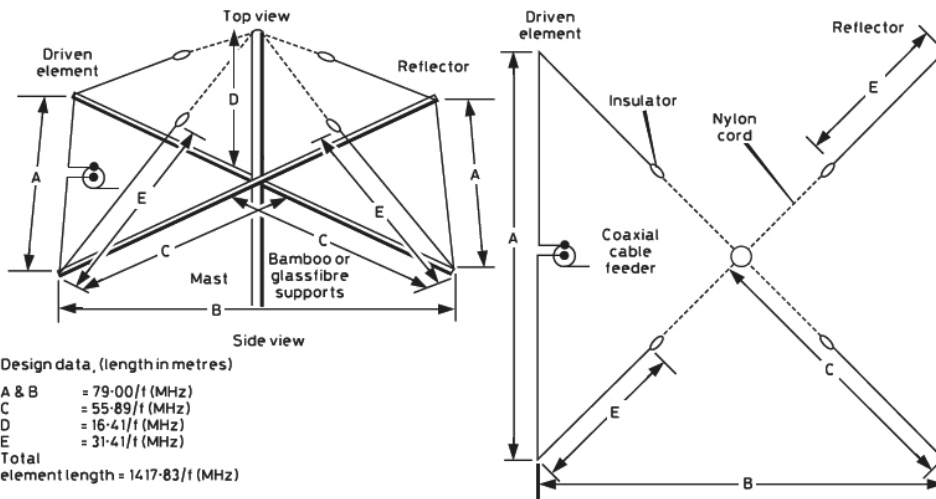

Design data, (length in metres)  
 $A \ \& \ B = 79.00/f \text{ (MHz)}$   
 $C = 55.89/f \text{ (MHz)}$   
 $D = 16.41/f \text{ (MHz)}$   
 $E = 31.41/f \text{ (MHz)}$   
 Total element length =  $1417.83/f \text{ (MHz)}$

### 147 - KE4PT OCEF All-Band Dipole

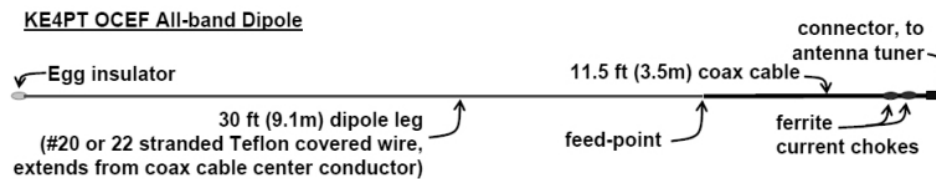

#### KE4PT Off center end fed (OCEF) All-band Dipole

Lengths are not critical, as long as they are not near a half wavelength on any frequency used.  
 Dipole radiating length is  $30+11.5=41.5 \text{ ft, or } 12.6 \text{ m.}$   
 Coax cable may be 50 or 75 ohm on left side of connector, short 50 ohm coax to antenna tuner.  
 Use antenna tuner for operation on any ham band 40m – 6m.  
 May be hung by Egg insulator at one end, or draped and drooped over a fiberglass pole.

#### References:

- [Antenna Toolkit - J. Carr](#)
- [Practical Antenna Handbook - J. Carr](#)
- [More Antenna Classics - C. Hutchinson](#)
- [Amateur Radio Techniques - P. Hawker](#)

[ARRL Antenna Handbook 1990-2007](#)  
[ARRL Handbook 1990-2009](#)  
[ARRL Antenna Compendium](#)  
[73 Magazine 1970-2002](#)  
[Funkamateur Magazine 1990-2011](#)  
[RSGB Handbook - 2007 - 2010](#)

[home](#)